

Small Projection port, Small View port Installation procedure

Materials required:

8	1/4" x 2" or longer lag, sheet metal, or wood screws.
4-8 Ft	Foam insulating material, caulk, rubber etc...
Misc.	2x4 lumber for framing window or other misc construction material

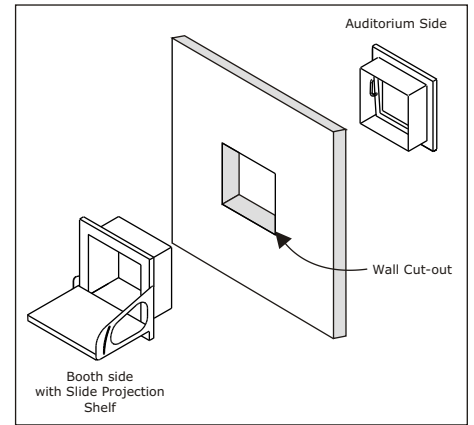

Introduction:

Thank you for your purchase, you are now the owner of a high quality, American made projection port. With proper care taken during installation and cleaning your port will provide a lifetime of outstanding performance.

Preparation:

The rough opening for your port should not be any less than 12 7/8 inches, and no more than 13 3/8 inches in either direction.

The ideal cut out size is 13 1/8 inches square.

Since wall construction techniques and materials vary from facility to facility, the following is intended only as a suggested procedure. Your wall may have different construction or be a different material all together. Consult a professional contractor on the proper installation of this port.

The port is best mounted when framed in with 2x4 lumber during the wall's construction. A carpenter should build in a suitable mounting location for your port based on it's dimensions, weight, and your projection equipment. (See Figure 1)

For existing walls, a rough opening is cut where the least amount of structural interference is caused. Consult a qualified carpenter. Be sure to test fit your port in its framing before finishing the wall.

Installation:

The surface should be finished with a rough opening in the drywall where the port is to mount.

The port can be secured directly to the frame and wall booth side first. The booth side is larger in size and the auditorium side (Glass side) slides into it. (See figure 2)

1/4 inch lag screws at least 2 inches in length should be used to secure the booth metal to the wall and 2x4 frame (Suitable wood or sheet metal screws can also be used). If desired, additional sealing/ sound dampening material can be applied to the booth side metal-to-wall contact surfaces.

The auditorium side of the port (Side with the glass) can be installed next, simply insert it through your cut out opening and into the booth side sleeve. Adhesive foam rubber or caulk can be used to seal the surface between the auditorium side metal and the wall if desired. This side should be sealed in some way to help prevent the escape of projector noise into the auditorium.

Again, use lag, wood or sheet metal screws to fasten the auditorium port metal to the frame and the wall.

(See figure 3)

If a Projector Shelf came with your port, or if you have ordered one separately, please see the following diagrams detailing its assembly. You will need a 3/16" Hex allen wrench.

Conclusion:

There is no clear cut "Right" way to install a projection port, but there are a few mistakes to avoid. Common mistakes include over tightening the mounting bolts, not framing in the port properly, reversing or inverting the booth and auditorium sides, and not properly sealing the auditorium metal-to-wall surface.

Proper installation ensures long product life, above average performance, and hassle free maintenance.



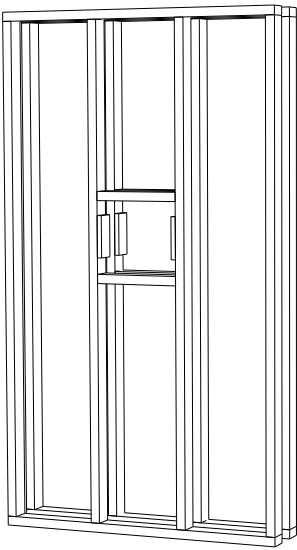

Figure 1
16 inch stud center
window framing

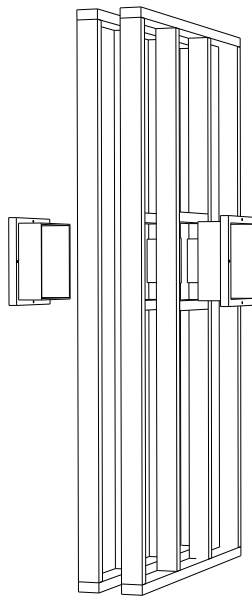

Figure 2
Test-Fitting
your port

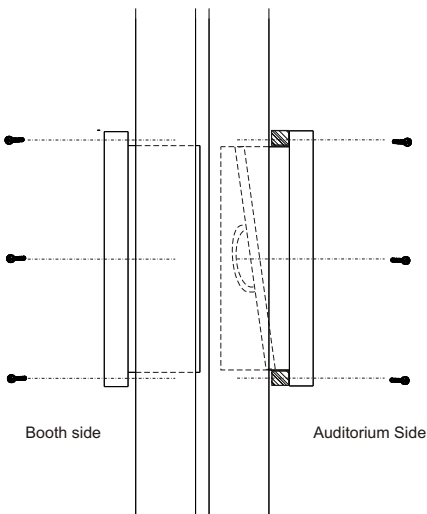
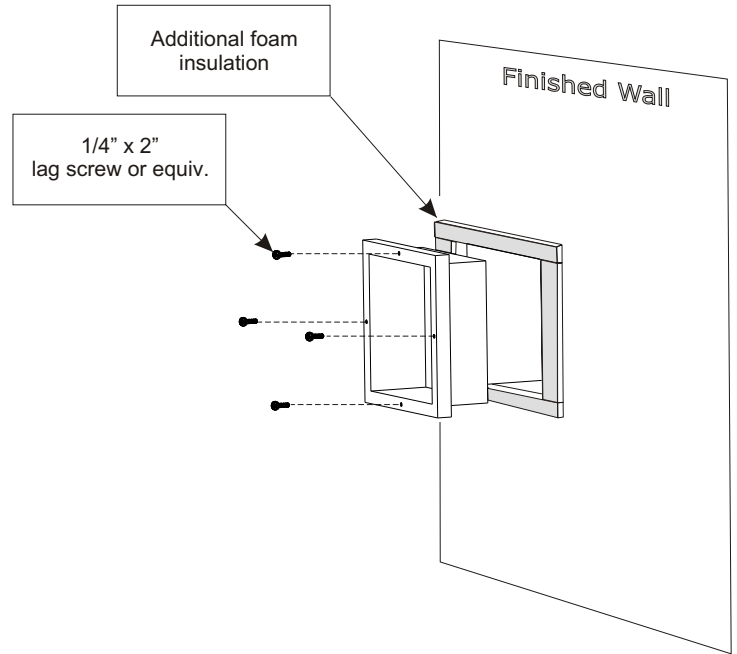
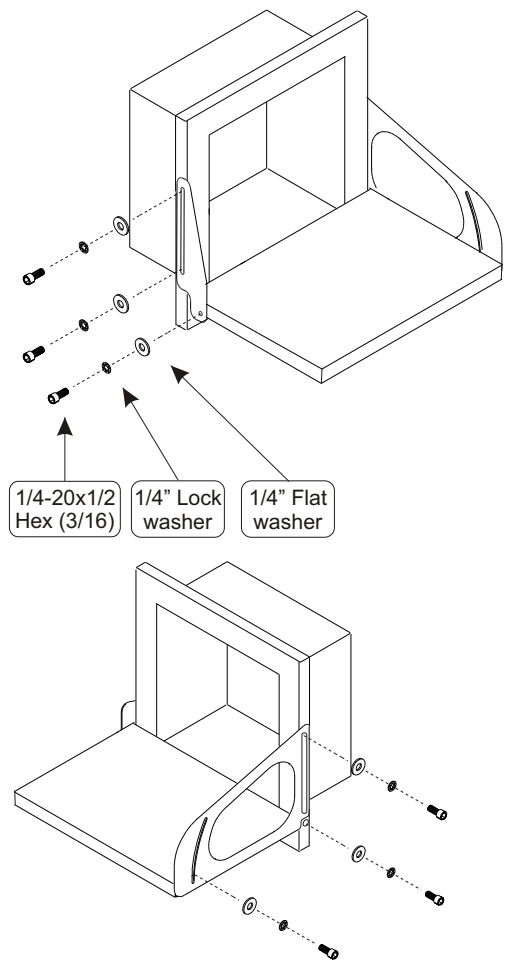

Figure 3
Cross-sectional view
of wall and port

Projector Shelf Assembly



Dimensions:

Overall Dimensions: 16" W x 16" H (40.6 cm x 40.6 cm)

Thru-Glass Dimension: 10 1/8" W x 10 1/4" H (25.7 cm x 25.7 cm)

Glass Angle: 7 Deg. from Vertical plane

Installed Wall Thickness: 5 1/2" Min - 12" Max (14 cm - 30.5 cm)

Wall Cut-out size: 13 1/8" W x 13 1/8" H (33.3 cm x 33.3 cm)

Approx. Port Weight: 26 lbs (11.8 Kg)

Projector Shelf Dimensions: 15 3/4" W x 11 3/4" D (40 cm x 29.9 cm)

Medium Slide Projection / View port, Medium View port Installation procedure

Materials required:

8	1/4" x 2" or longer lag, sheet metal, or wood screws.
6-11.5 Ft	Foam insulating material, caulk, rubber etc...
Misc.	2x4 lumber for framing window or other required construction materials

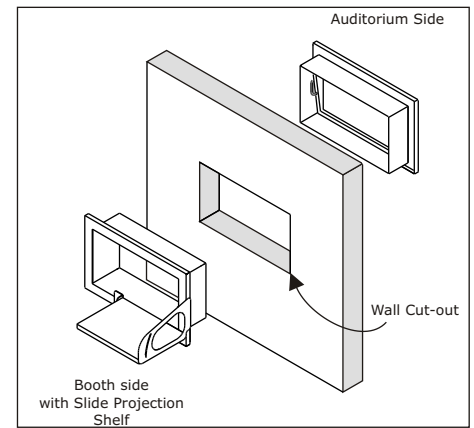

Introduction:

Thank you for your purchase, you are now the owner of a high quality, American made slide projection / view port. With proper care taken during installation and cleaning your port will provide a lifetime of outstanding performance.

Preparation:

The rough opening for your port should not be any less than 12 7/8 inches high and 23 inches wide, and no more than 13 3/8 high and 23 1/2 inches wide.

The ideal cut out size is 13 1/8 inches high and 23 1/8 inches wide.

Since wall construction techniques and materials vary from facility to facility, the following is intended only as a suggested procedure. Your wall may have different construction or be a different material all together. Consult a professional contractor on the proper installation of this port.

The port is best mounted when framed in with 2x4 lumber during the wall's construction. A carpenter should build in a suitable mounting location for your port based on it's dimensions, weight and your projection equipment. (See Figure 1) For existing walls, a rough opening is cut where the least amount of structural interference is caused. Consult a qualified carpenter. Be sure to test fit your port in its framing before finishing the wall.

Installation:

The surface should be finished with a rough opening in the drywall where the port is to mount.

The port can be secured directly to the frame and wall booth side first. The booth side is larger in size and the auditorium side (Glass side) slides into it. (See figure 2)

1/4 inch lag screws at least 2 inches long should be used to secure the booth metal to the wall and 2x4 frame (Suitable wood or sheet metal screws can also be used). If desired, additional sealing/ sound dampening material can be applied to the booth side metal-to-wall contact surfaces.

The auditorium side of the port (Side with the glass) can be installed next, simply insert it through your cut out opening and into the booth side sleeve. Adhesive foam rubber or caulk can be used to seal the surface between the auditorium side metal and the wall if desired. This side should be sealed in some way to help prevent the escape of projector noise into the auditorium.

Use lag, wood or sheet metal screws to fasten the auditorium port metal to the frame and the wall. (See figure 3) If a Projector Shelf came with your port, or if you have ordered one separately, please see the following diagrams detailing its assembly. You will need a 3/16" Hex allen wrench.

Conclusion:

There is no clear cut "Right" way to install a projection port, but there are a few mistakes to avoid. Common mistakes include over tightening the mounting bolts, not framing in the port properly, reversing/ inverting the booth and auditorium sides, and not properly sealing the auditorium metal-to-wall surface.

Proper installation ensures long product life, above average performance, and hassle free maintenance.



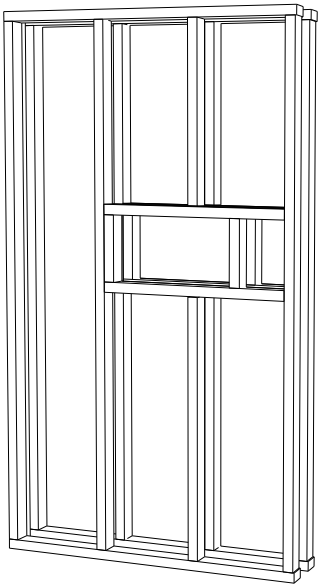

Figure 1
16 inch stud center
window framing

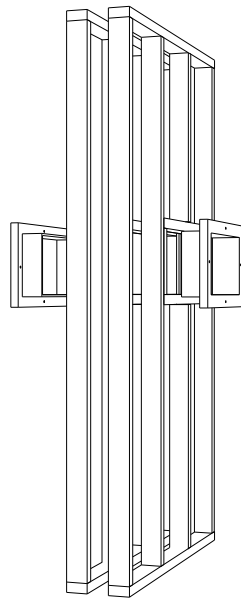
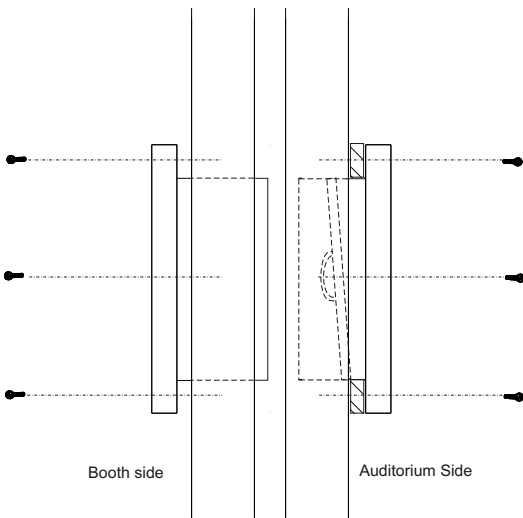
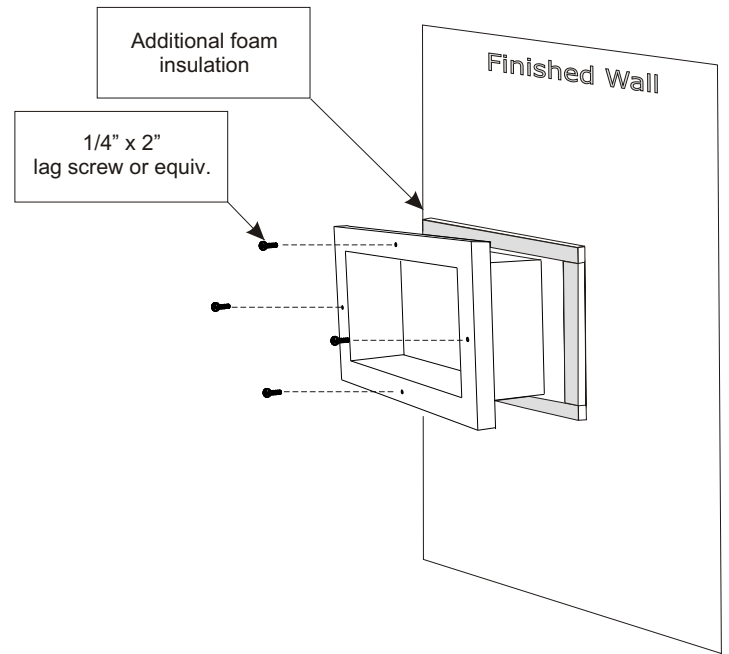
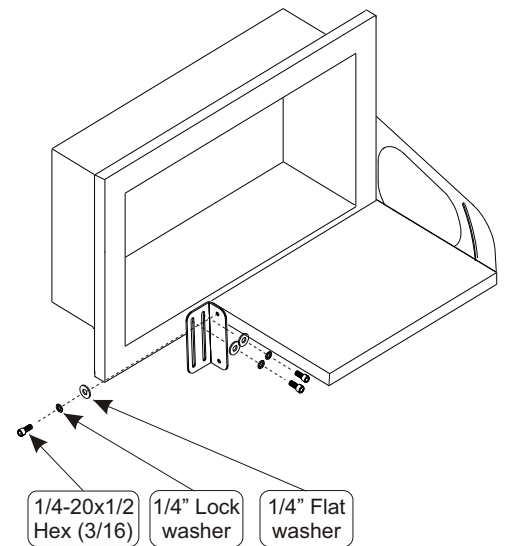

Figure 2
Test-Fitting
your port



Cross-sectional view
of wall and port

Projector Shelf Assembly



Dimensions:

Overall Dimensions: 26" W x 16" H (66 cm x 40.6 cm)

Thru-Glass Dimension: 20" W x 10 1/8" H (50.8 cm x 25.7 cm)

Glass Angle: 7 Deg. from Vertical plane

Installed Wall Thickness: 6 1/4" Min - 13" Max (15.9 cm - 33 cm)

Wall Cut-out size: 23 1/8" W x 13 1/8" H (58.74 cm x 33.3 cm)

Approx. Weight: 37 lbs (16.8 Kg)

Projector Shelf Dimensions: 15 3/4" W x 11 3/4" D (40 cm x 29.9 cm)

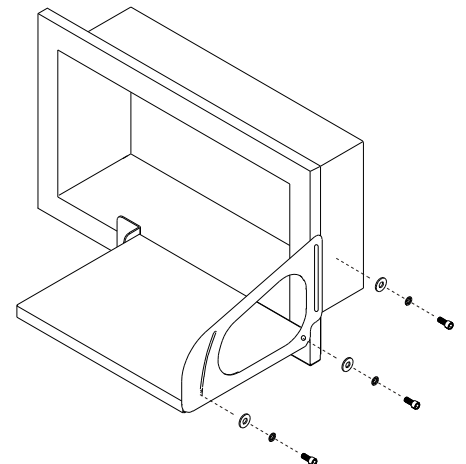

Projection port Installation procedure

Materials required:

12	1/4" x 2" or longer lag, sheet metal, or wood screws.
8-16 Ft	Foam insulating material, caulk, rubber etc...
Misc.	2x4 lumber for framing window or misc construction materials

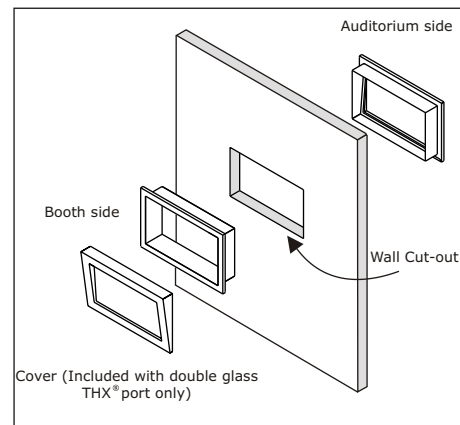

Introduction:

Thank you for your purchase, you are now the owner of a high quality, American made projection port. With proper care taken during installation and cleaning your port will provide a lifetime of outstanding performance.

Preparation:

The rough opening for your port should not be any less than 18 1/4 inches high and 30 1/8, and no more than 18 1/2 inches high and 31 1/2 inches wide.

The ideal cut out size is 18 3/8 high and 30 7/8 inches wide.

Since wall construction techniques and materials vary from facility to facility, the following is intended only as a suggested procedure. Your wall may have different construction or be a different material all together. Consult a professional contractor on the proper installation of this port.

The port is best mounted when framed in with 2x4 lumber during the wall's construction. A carpenter should build in a suitable mounting location for your port based on it's dimensions, weight, and your projection equipment. (See Figure 1)

For existing walls, a rough opening is cut where the least amount of structural interference is caused. Consult a qualified carpenter. Be sure to test fit your port in its framing before finishing the wall.

Installation:

The surface should be finished with a rough opening in the drywall where the port is to mount.

The port can be secured directly to the frame and wall booth side first. The booth side is larger in size and the auditorium side (Glass side) slides into it. (See figure 2)

1/4 inch lag screws at least 2 inches in length should be used to secure the booth metal to the wall and 2x4 frame (Suitable wood or sheet metal screws can also be used). If desired, additional sealing/ sound dampening material can be applied to the booth side metal-to-wall contact surfaces. The booth side of the port should be installed with the hooks for hanging the THX ® cover pointing upward.

The auditorium side of the port (Side with the glass) can be installed next, simply insert it through your cut out opening and into the booth side sleeve. Adhesive foam rubber or caulk can be used to seal the surface between the auditorium side metal and the wall if desired. This side should be sealed in some way to help prevent the escape of projector noise into the auditorium.

Again, use lag, wood or sheet metal screws to fasten the auditorium port metal to the frame and the wall. (See figure 3)

The auditorium side must be oriented properly depending on port configuration. If a THX ® cover is to be used, the glass should "lean toward" the auditorium. If no cover will be used, the glass should "lean toward" the projection booth. This concept is illustrated in figure 3. Just remember that when using two panes of glass, the glass must be at opposite angles or form a "V" .

Conclusion:

There is no clear cut "Right" way to install a projection port, but there are a few mistakes to avoid. Common mistakes include over tightening the mounting bolts, not framing in the port properly, reversing the booth and auditorium sides, and not properly sealing the auditorium metal-to-wall surface.

Proper installation ensures long product life, above average performance, and hassle free maintenance.



THX is a registered trademark of Lucasfilms Ltd

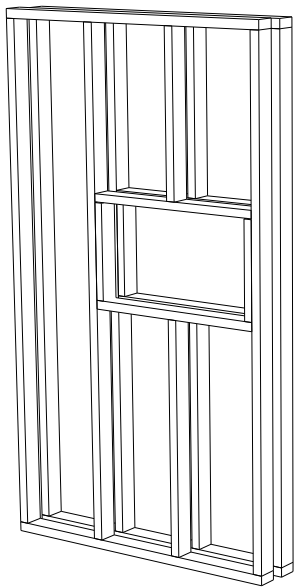

Figure 1
16 inch stud center
window framing

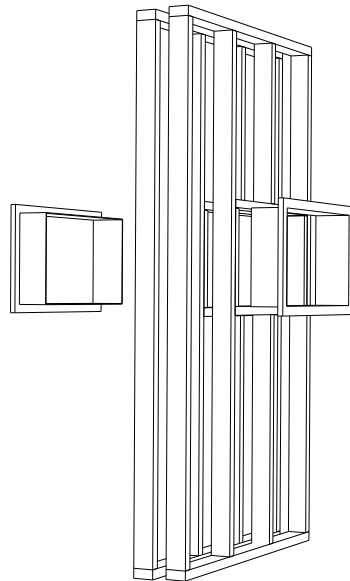
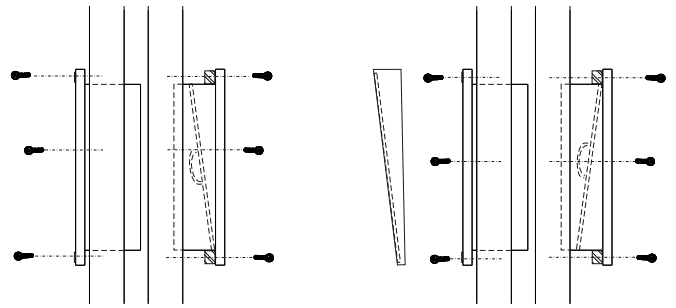

Figure 2
Test-Fitting
your port



Projection port installed without THX
cover (note glass angle)

Projection port installed with THX
cover (note glass angle)

Cross-sectional view
of wall and port

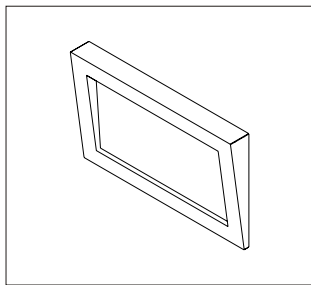

Cover (Included with double glass
THX port only)

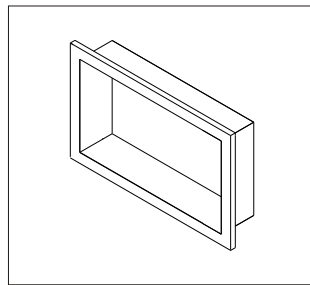

Booth side

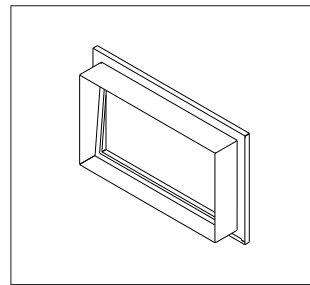

Auditorium side

Component
Identification

1/4" x 2"
lag screw or equiv.

Additional foam
insulation

Finished Wall

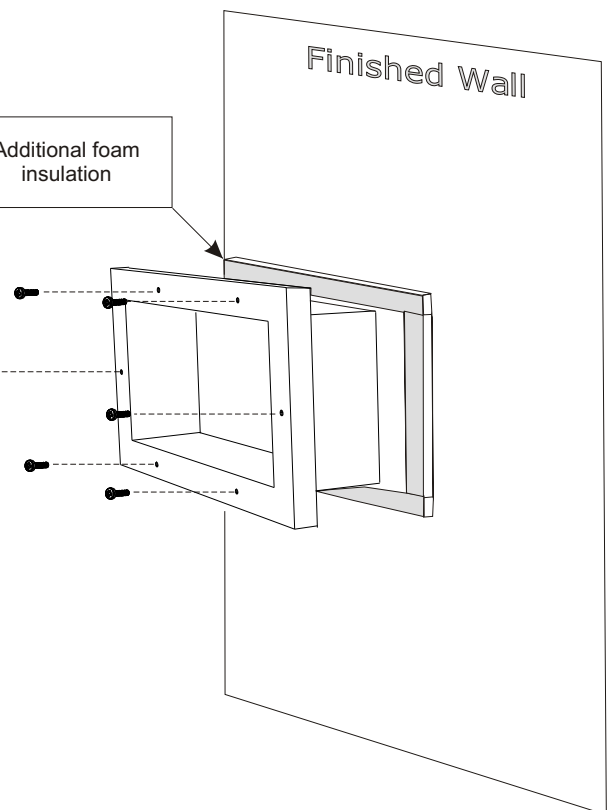

Dimensions:

Overall Dimensions: 34 1/4 in W x 21 1/4 in H (87 cm x 54 cm)

Glass Angle: 7 Deg. from Vertical

Thru-Glass Dimension with Wireway: 24 3/8 in W x 15 in H (62 cm x 38 cm)

Thru-Glass Dimension without Wireway: 30 3/8 in W x 15 in H (77 cm x 38 cm)

Installed Wall Thickness: 6 1/4 in Min - 13 in Max (15.9 cm x 33 cm)

Wall Cut-out Dimensions: 30 5/8 in W x 17 5/8 in H (77.8 cm x 44.8 cm)

Approx Port Weight: 55 lbs (24.9 kg). (82 lbs. (37.2 kg) with THX® cover)

Media Projection Shelf Installation procedure

Materials required:

Minimum 4 1/4" x 2" or longer lag, sheet metal, or wood screws

Introduction:

Thank you for your purchase, you are now the owner of a high quality, American made Media Projection Shelf. With proper care taken during installation and cleaning, your shelf will provide a lifetime of outstanding performance.

Preparation:

Once your projection port is installed, a location can be marked on the wall or port frame for mounting the Media Shelf. This location is dependent on the projection equipment and port you are using. The mounting plate is 10 inches high x 26 inches long and has evenly spaced holes to accept 1/4 inch hardware on 4 inch horizontal centers. (See Figure 1)

The shelf is adjustable from 1 1/2 inch to 3 3/4 inches above the top of the mounting plate.

Installation:

The Shelf mounting plate should be secured to the wall using 1/4 inch by 2 inch or longer screws. A minimum of 4 screws should be used to mount the shelf to the wall. If hardware cannot be positioned so as to penetrate a wall stud, an appropriate mounting adapter must be fabricated. Your wall may be of different construction or a different material all together than the examples shown. Consult a contractor.

The remainder of the shelf parts are then assembled according to the instructions given in the following diagrams. The only tool required for assembly and adjustment is a 3/16 hex or allen wrench.

Conclusion:

Proper installation ensures long product life, above average performance, and hassle free adjustment. The Media Projection Shelf's 75 pound load rating is dependent on proper mounting. If the shelf is improperly secured to the wall, the shelf could fall causing equipment damage. Strong International cannot be held liable or responsible for any damages caused by the improper application or installation of this assembly.

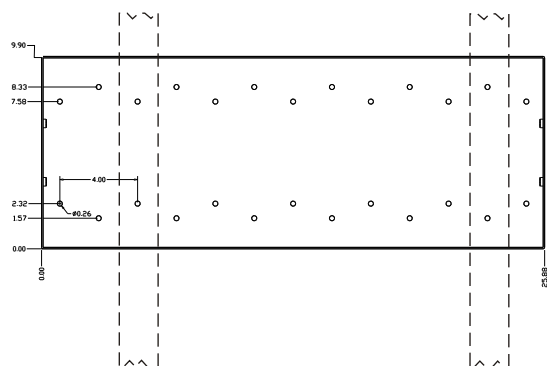
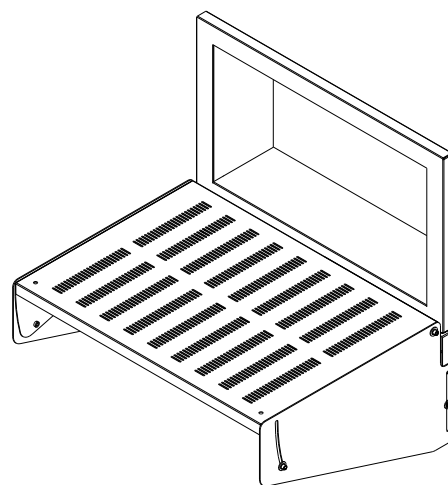
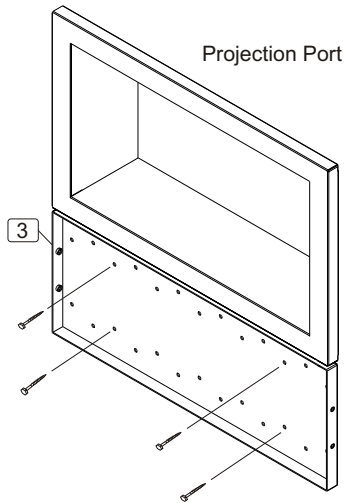

Figure 1
Diagram of the shelf mounting plate,
holes shown accept 1/4 inch hardware



STEP 1: Secure bracket (3) to wall under projection port.
 Note: Bracket is symmetrical.



*Note: Wall mounting hardware is not included.

STEP 2: Assemble side panels (2) to each end of vented shelf (1) with hardware (4)(5)(6).

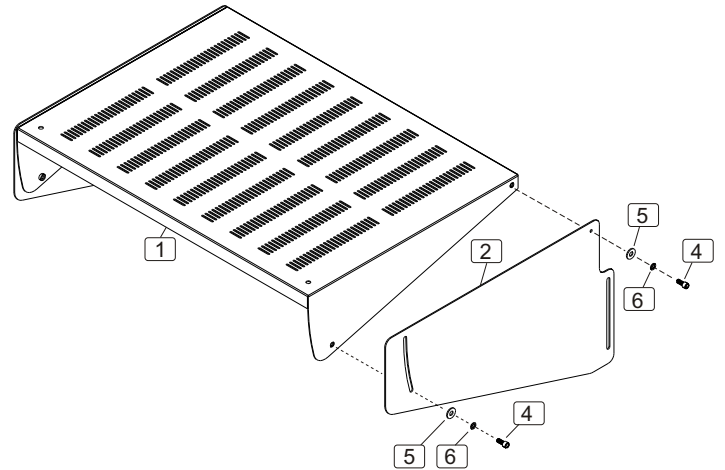

STEP 3: Mount shelf assembly to bracket (3) with hardware (4)(5)(6). Make vertical and incline adjustments and tighten all screws.

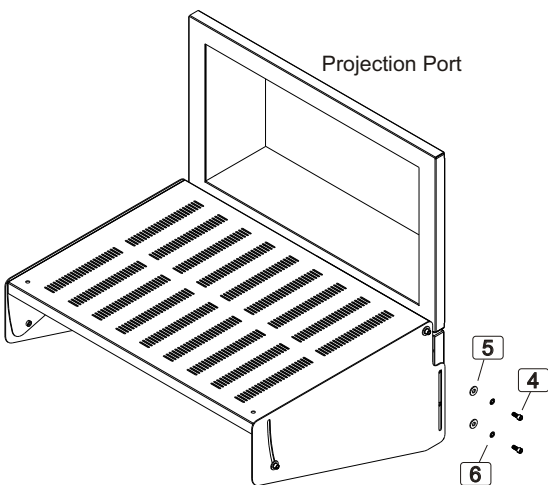

Parts List

- 1) B2912 Vented Shelf (1)
- 2) B2913 Side Panel (2)
- 3) B2914 Mounting Bracket (1)
- 4) 1/4-20 x 1/2" Socket Hd. Cap Screw (8)
- 5) 1/4" Flat Washer (8)
- 6) 1/4" Internal Lock Washer (8)

Projection Port Extender Installation

(13-18" Version)

Introduction:

Strong's projection port extenders were designed to make it possible to install a Strong projection port in a wall that would ordinarily be too deep. The standard range of wall depth is from 6.25 to 13 inches. Our extenders allow for sealed installations in walls from 13 to 18 inches deep.

Installation:

To install the extenders, it will be necessary to drill the port frame and either use self-tapping sheet metal screws or tap the holes for the required hardware. It is recommended that #10 screws are used with a length of 1/4" - 3/8".

Assembly:

As shown in the following illustrations, the four extender pieces are designed to fit INSIDE the port from the booth side. They extend over to meet the auditorium side, and are fastened into place. It is important to note that the extender metal is designed to fit over the OUTSIDE of the auditorium frame.

First, the flat end of the extension piece should be held in place along the bottom of the port, it should be positioned forward or rearward so that it extends as far as needed. The bend should be pointing up. Mark the port for drilling using the holes in the extender as a guide. Drill and secure with sheet metal screws. Repeat this process in a clockwise direction until you have a complete rectangle.

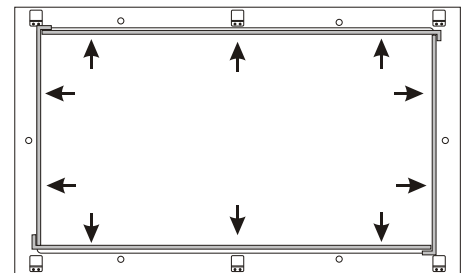
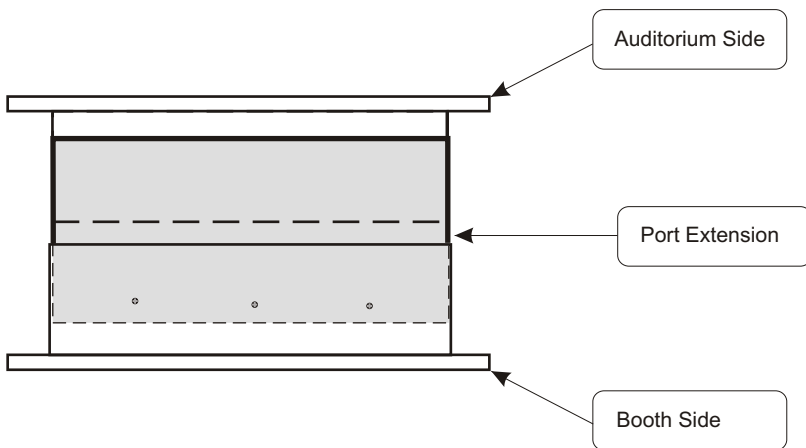

Drill and secure with self tapping sheet metal screws

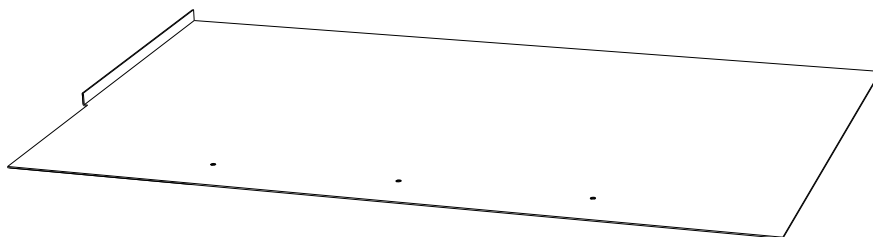

Medium Projection \ View Port Extender Installation

(13-18" Version)

The installation of the Medium Projection / View port extender is basically the same as that listed above for the Projection port. The only difference is the size of the plates that make up the extender. See the following diagrams for medium extender installation.

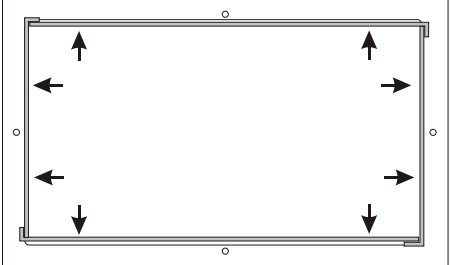
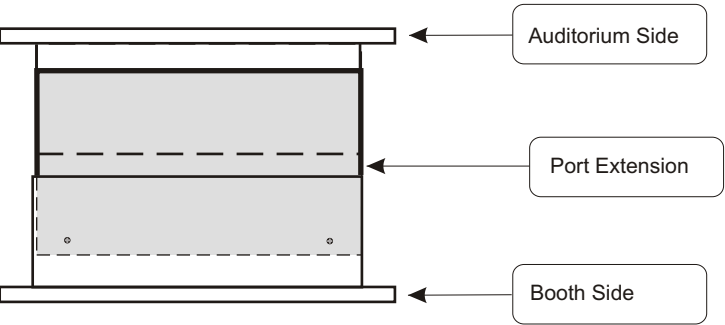

Drill and secure with self tapping sheet metal screws

Small Projection Port and Small View Port Extender Installation

(13-18" Version)

The installation of the Small Projection and Small View port extender is basically the same as that listed above for the other ports. The only difference is the size of the plates that make up the extender. See the following diagrams for small extender installation.

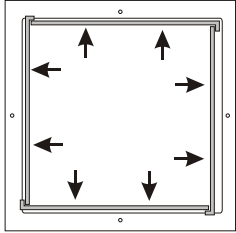
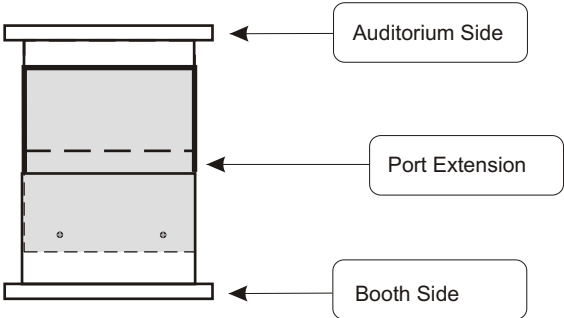

Drill and secure with self tapping sheet metal screws

Projection Port Extender Installation

(18-22" Version)

Strong's 18-22" projection port extenders were designed to make it possible to install a Strong projection port in a wall that would ordinarily be too deep. The standard range of wall depth is from 6.25 to 13 inches. Our extenders allow for sealed installations in walls from 18 to 22 inches deep.

To install the extenders, it will be necessary to drill the port frame and either use self-tapping sheet metal screws or tap the holes for the required hardware. It is recommended that #8 -#10 screws are used with a length of 3/8".

As shown in the following illustrations, the four extender pieces are designed to fit **INSIDE** the port from the booth side. They extend over to meet the auditorium side, and are fastened into place. It is important to note that the extender metal is designed to fit over the **OUTSIDE** of the auditorium frame.

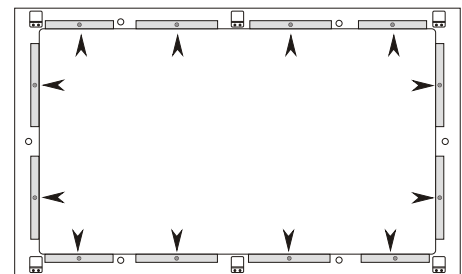
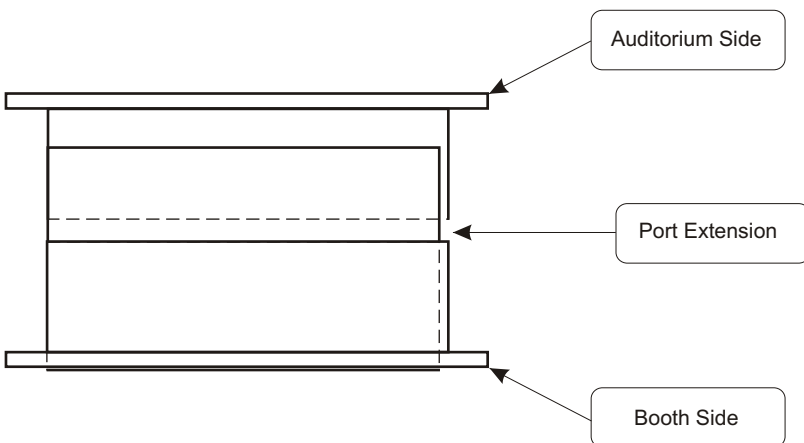

Drill these locations and
secure with 12 3/8"
screws



Medium Projection \ View Port Extender Installation

(18-22" Version)

The installation of the Medium Projection / View port extender is basically the same as that listed above for the Projection port. The only difference is the size of the plates that make up the extender. See the following diagrams for medium extender installation.

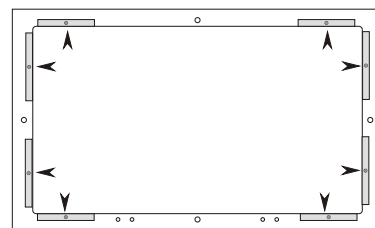
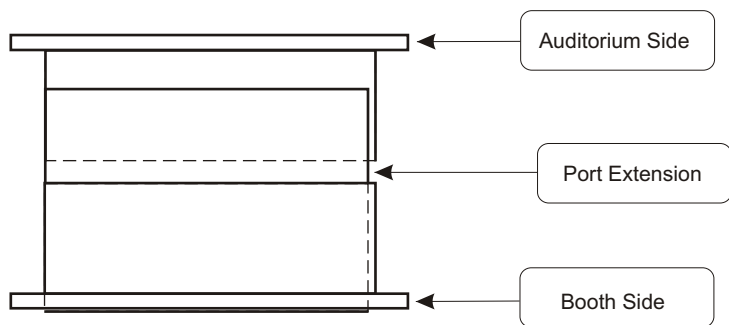

Drill these locations and secure with 8 3/8" screws

Small Projection Port and Small View Port Extender Installation

(18-22" Version)

The installation of the Small Projection and Small View port extender is basically the same as that listed above for the other ports. The only difference is the size of the plates that make up the extender. See the following diagrams for small extender installation.

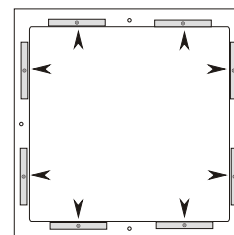
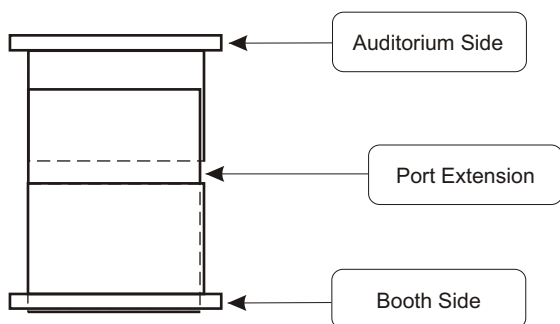

Drill these locations and secure with 8 3/8" screws