

**CNI-200**  
***Cinema Network Interface***

PRELIMINARY



August 22, 2006



# Table of Contents

Definitions . . . . .	0
Introduction . . . . .	1
Description . . . . .	1
Main Control Unit . . . . .	1
Main CPU Board . . . . .	2
Power Supply . . . . .	4
Termination Board . . . . .	5
Relay Outputs . . . . .	7
Bypass Mode . . . . .	7
Termination Board Wiring . . . . .	7
Outputs . . . . .	7
Manual Switches . . . . .	9
Inputs . . . . .	10
Supervisory Setup . . . . .	11
Network Setup . . . . .	11
Digital I/O Setup . . . . .	12
Input Functions . . . . .	12
Output Functions . . . . .	13
Supervisory Input/Output Setup Screens . . . . .	14
Manual Control Screen . . . . .	15
CNI-200 Program Editor . . . . .	16
Application Example . . . . .	17
SPA-7 to CNI-200 Wiring . . . . .	17
Program . . . . .	21
Manual Override Switches . . . . .	22

## Definitions

<b>Digital Client</b>	This is the Digital Cinema Management system or a component of the system that communicates with the CNI-200 Cinema Network Interface.
<b>CAI</b>	Cinema Automation Interface Protocol. This is the Ethernet and RS-232 serial protocol designed for the Digital Cinema System interface. See the <i>Command Interface Protocol Specification</i> for complete details.
<b>KDI</b>	Keyboard & Display Interface Protocol. This is an Ethernet protocol that allows a client to utilize the CNI-200's display and keypad. See the <i>Command Interface Protocol Specification</i> for complete details.
<b>Host</b>	This is the device, software, etc. that connects to the CNI's Ethernet or LSN Gateway utilizing the proprietary protocol for system configuration, monitoring and control. CineSuite Software utilizes this protocol.
<b>LIN</b>	Local I/O Network. This is a powered RS-485 serial network that support local I/O devices such as the 39440 and 39490 termination boards.
<b>LSN</b>	Local Synchronous Network. This an isolated RS-485 network used for inter-system communications.

## Introduction

The CNI-200 Cinema Network Interface is a cinema control system that provides a link between the digital cinema system and the existing film equipment. The CNI-200 exchanges status and control information with the digital cinema equipment via a standard IP-based (Ethernet) network or an RS-232 serial link to provide full automatic control of the booth and auditorium functions in coordination with the existing film automation system. It allows the switching between film and digital content at any time during a presentation. A Bypass feature disables CNI-200 control handing off control to the existing film automation.

The CNI features configurable digital outputs and inputs for interfacing to the film automation and cinema equipment (such as lights, masking, start, cues, etc). Internal user programs handle the tedious work of controlling the show event sequences. This relieves the digital cinema client from having to do the low level I/O control. The digital client needs only to send cues via the serial link and the CNI controls the entire presentation passing control to the film automation as required. However, outputs can be configured for exclusive control by the digital client. Also, all digital inputs are available to the digital client as well.

The CNI-200 incorporates a 1/4 VGA backlit display and keypad that is used for setup and displaying system status information. The digital client can also use the display and keypad for it's own purposes, such as displaying digital projector and show status. It could also be used to setup or modify the digital system.

The CNI-200 is connected to the Termination I/O board via a serial link. This allows the termination board to be installed in a different location than the main control/display unit. This can be advantageous in that the termination board can be mounted close to the film automation equipment terminations while the main control/display unit can be mounted in a more suitable location.

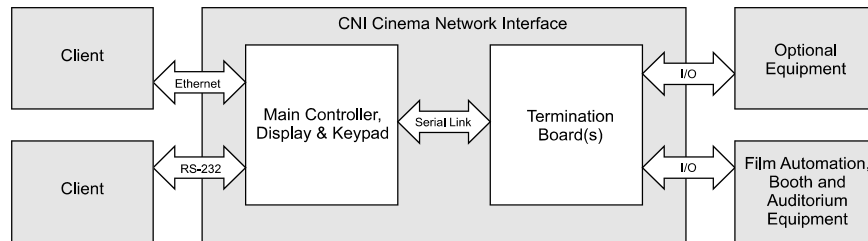

The CNI supports up to 2 digital cinema clients. See the *Command Interface Protocol Specification* manual for details of the serial communications protocol.

## Description

### Main Control Unit

The main control is housed in a 4U standard 19" rack mountable steel cabinet. The unit contains the system power supply, main control board and user interface. The front panel has provisions for optional manual switches. These switches can be used for emergency manual control or other purposes. The keypad and display are used for system setup, manual control and monitoring run time show events.

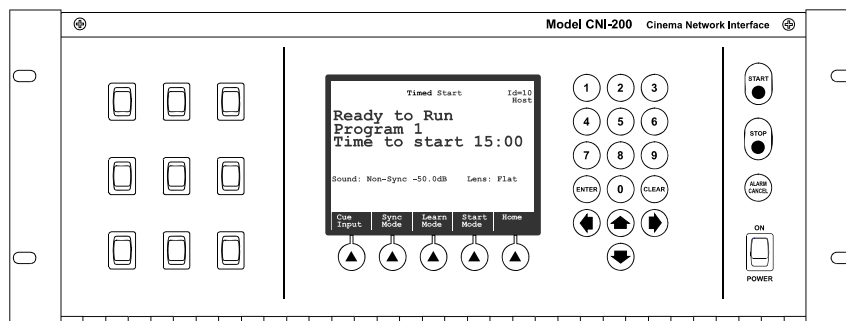

CNI-200 Front Panel

The control panel is hinged to provide access to the internal electronics. Remove the two panel screws to open the unit. This exposes the Main CPU board and Power Supply.

**Main CPU Board**

The Main CPU board features several serial communication ports including an Ethernet port. Some of these ports have a specific function and others are for future development. There are 3 banks of DIP switches used for basic system configuration. The LEDs provide an indication of power supply and serial communications status.

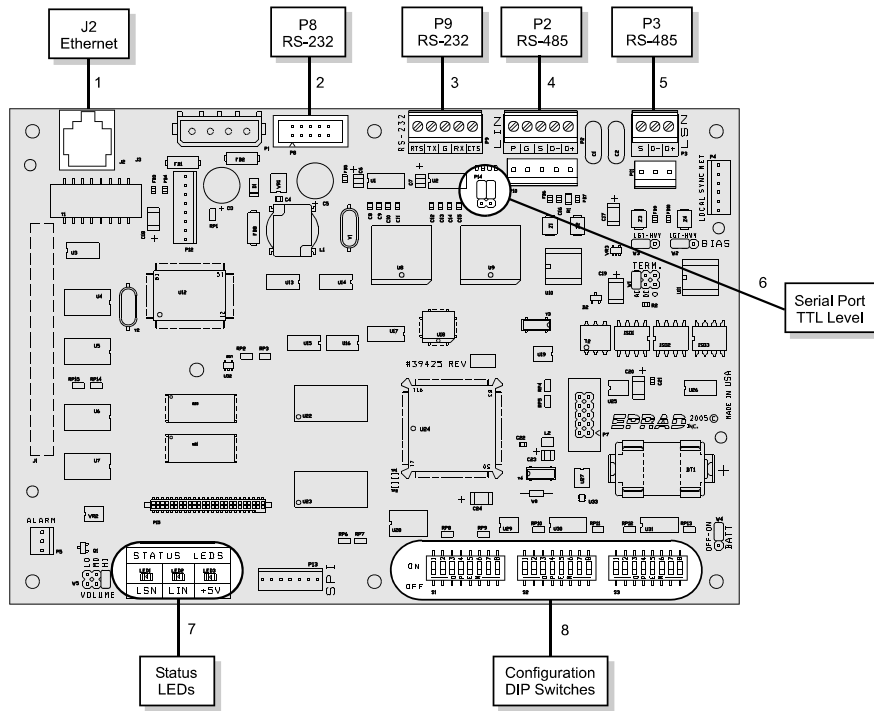

- 1) Ethernet - J2 a 10Base-T Ethernet RJ-45 connector. This connection is currently used for the CAI, KDI and Host protocols. It also features a embedded web browser interface.
- 2) RS-232 - P8 is an RS-232 port currently used to set up the Ethernet parameters. The same parameters can be set up from the CNI-200 front panel.
- 3) RS-232 - P9 is an RS-232 port used to support the CAI protocol.
- 4) RS-485 - P2 and P10 are the LIN (Local I/O Network) connections. Serial data and power support the 39440 termination board and any other future LIN devices.
- 5) RS-485 - P3 and P11 are connectors for the isolated RS-485 LSN port.
- 6) Serial Port - P14 is a spare serial port. This is for future use.
- 7) Status LEDs - LED1 displays the status of the LSN and LED2 displays the status of the LIN. A fast blink indicates that the CNI is communicating with a network device. LED3 is the +5 volt computer voltage.
- 8) Configuration DIP Switches - S1 through S3 are used for CNI configuration. These switch definitions are the same as the eCNA-200 switches. See the *eCNA-200 Setup and Operation* manual for a detailed explanation of each of the switch functions.

**DIP Switch Definitions**

S1	Function	ON	OFF
S1-1	Boot Loader	Force Boot Loader on Power Up	Application on Power Up *
S1-2	Supervisory Defaults	Force Defaults on Power Up	Do Not Overwrite *
S1-3	LSN Id 20H bit	Value = 20H (32 Decimal)	Value = 00H (0 Decimal) *
S1-4	LSN Id 10H bit	Value = 10H (16 Decimal)	Value = 00H (0 Decimal) *
S1-5	LSN Id 08H bit	Value = 08H (8 Decimal)	Value = 00H (0 Decimal) *
S1-6	LSN Id 04H bit	Value = 04H (4 Decimal)	Value = 00H (0 Decimal) *
S1-7	LSN Id 02H bit	Value = 02H (2 Decimal)	Value = 00H (0 Decimal) *
S1-8	LSN Id 01H bit	Value = 01H (1 Decimal) *	Value = 00H (0 Decimal)

S2	Function	ON	OFF
S2-1	Manual Control Screen	Enable *	Disable
S2-2	Password	Enable *	Disable
S2-3	Check Focus Delay	Enable	Disable *
S2-4	Fire Stop	Enable	Disable *
S2-5	<i>Not Defined</i>	<i>Not Defined</i>	<i>Not Defined</i> *
S2-6	<i>Not Defined</i>	<i>Not Defined</i>	<i>Not Defined</i> *
S2-7	Host Event Log	Enable *	Disable
S2-8	Cinema Automation Interface	Enable *	Disable

S3	Function	ON	OFF
S3-1	<i>Not Defined</i>	<i>Not Defined</i>	<i>Not Defined</i> *
S3-2	<i>Not Defined</i>	<i>Not Defined</i>	<i>Not Defined</i> *
S3-3	<i>Not Defined</i>	<i>Not Defined</i>	<i>Not Defined</i> *
S3-4	<i>Not Defined</i>	<i>Not Defined</i>	<i>Not Defined</i> *
S3-5	<i>Not Defined</i>	<i>Not Defined</i>	<i>Not Defined</i> *
S3-6	Check Focus Delay Alarm	Disable RCM / RSM Alarm on Start *	Enable RCM / RSM Alarm on Start
S3-7	Host Select	TCP/IP Host Support	LSN Gateway Host Support *
S3-8	IP Defaults	Force Defaults on Power Up	Do Not Overwrite *

\* Default

## Power Supply

The Power Supply board provides clean, regulated DC power to the system. The CNI can be powered by 120VAC/60Hz or 220VAC/50Hz line voltage.

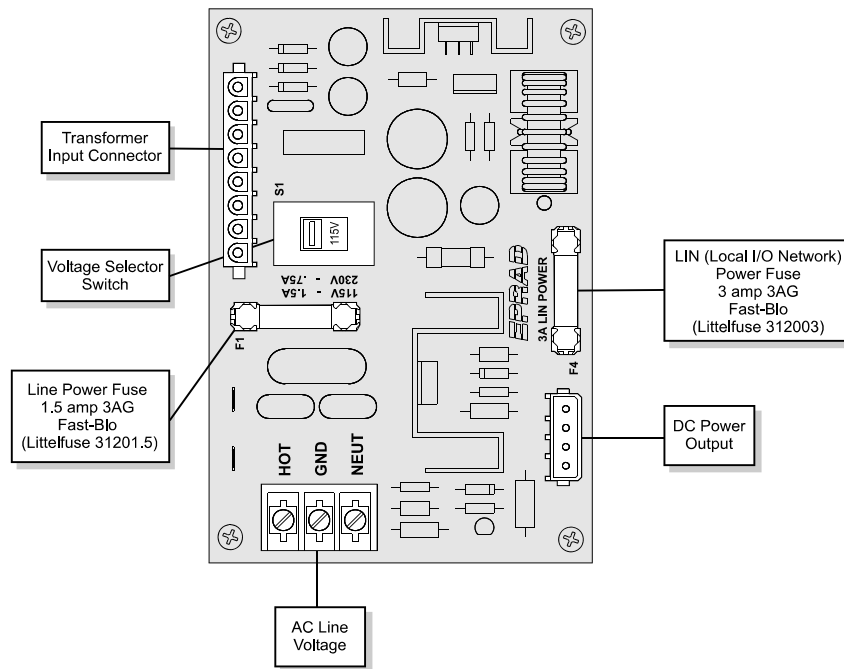

- Transformer Input Connector - Power transformer connector.
- Voltage Selector Switch - 120V/220V line voltage selector switch.
- Line Power Fuse - Power transformer line input protection fuse.
- AC Line Voltage - 120VAC/60Hz or 220VAC/50Hz line voltage feed.
- DC Power Output - Computer and LIN power. Regulated +24, -24 and +18 volts DC.
- LIN Power Fuse - Local I/O Network protection fuse for the +18 volts DC.



**Termination Board**

The 39440 CNI Termination board communicates with the Main Control Unit via an RS-485 serial link (LIN). It is also powered by the Main Control Unit. This allows the board to be mounted away from the Main Control Unit in a convenient location. The board features 16 outputs and 8 digital inputs. All outputs are relay contact closures and all inputs are optically isolated. The drawing below highlights the major features of the board.

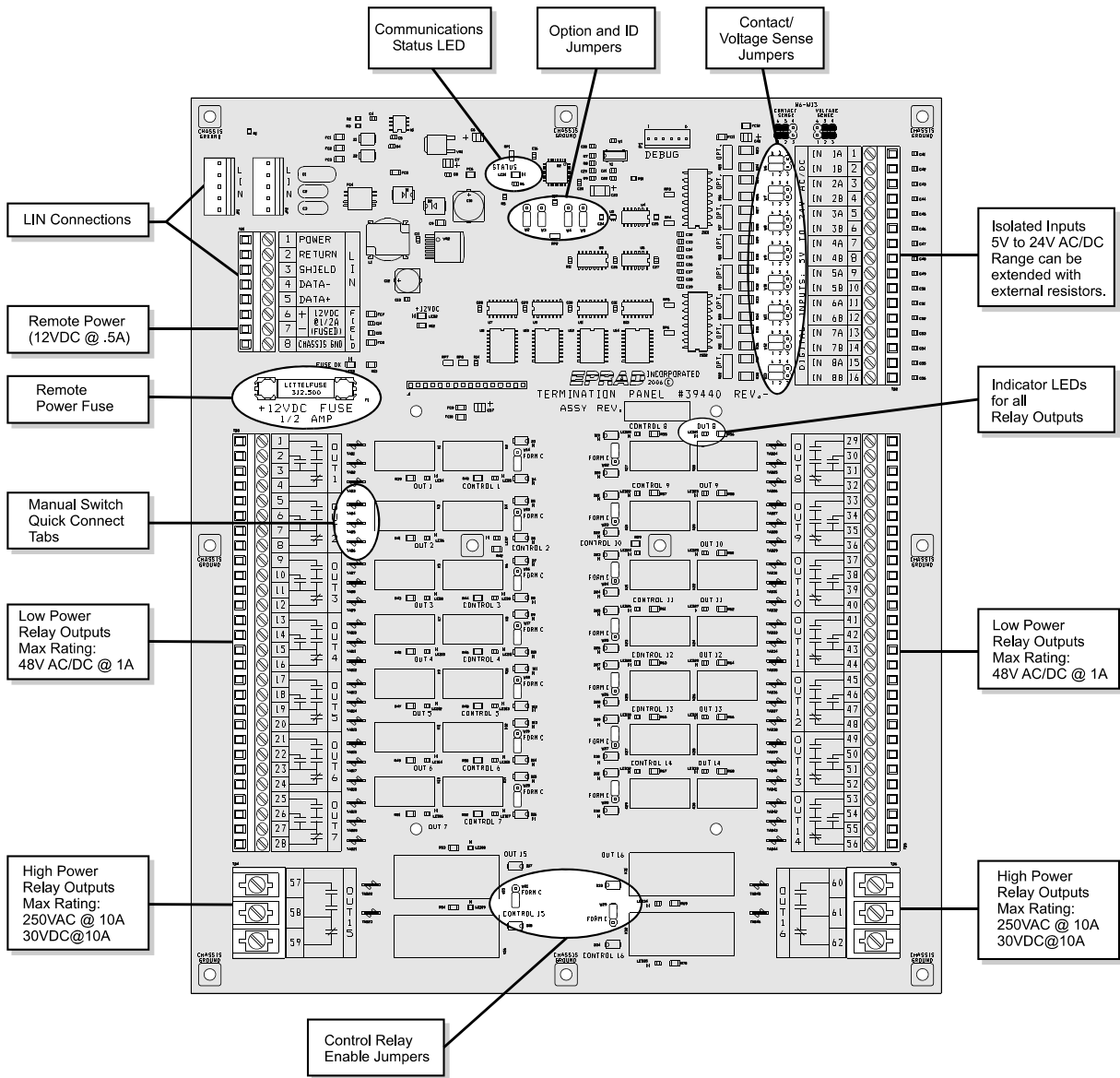

- Status LED - This LED displays the status of the on board micro-controller and LIN communications.
- Option and ID Jumpers - W2, W3, W5 are undefined. W4 selects the LIN Id (Board #1 or Board #2)
- Contact/Voltage Sense Jumpers - Sets up input for contact or voltage sense.
- Inputs - 8 non-polarized isolated inputs.
- Output LEDs - LEDs on all relays indicate that the relay is energized.
- Outputs - 16 relay outputs
- Control Relay Enable Jumpers - Enable Bypass control relays or Form C contact.
- Manual Switch Quick Connects - 3/16 inch quick connect tabs for optional manual switches.

- Remote Power - +12 volts DC at 1/2 amp for powering optional equipment.
- LIN - Local I/O Network. Connects to the Main Control Unit.

Important: The termination board uses copper planes in particular locations of the board that are connected to the mounting holes. These provide a low impedance path for high frequency electrical noise to earth ground. It is important that all mounting holes are connected to a grounded metal chassis with metal screws.

The drawing below is a functional block diagram of the termination panel.

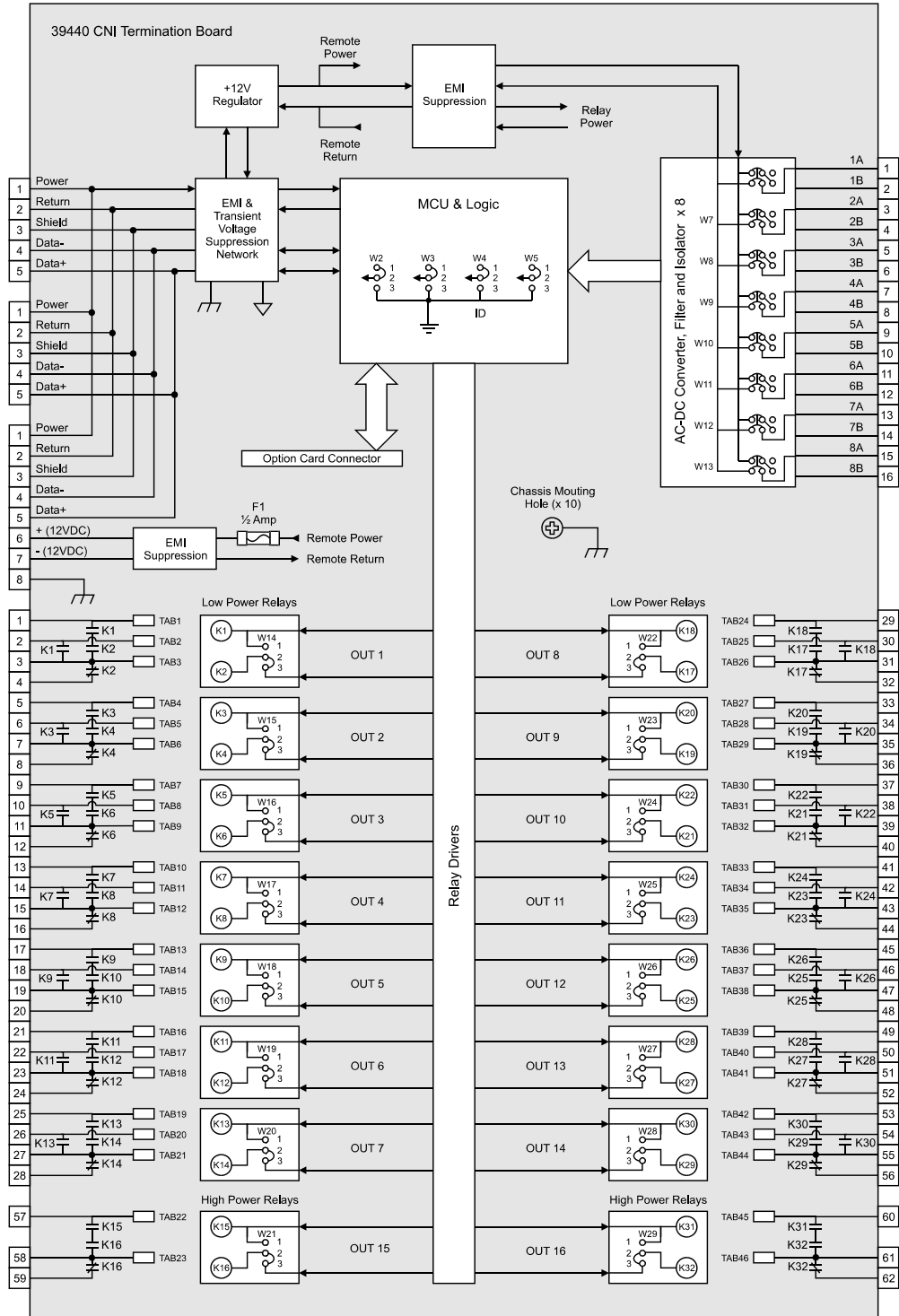

**Relay Outputs**

The termination board is equipped with 14 low power and 2 high power relay outputs. All of these outputs are dry relay contacts. Outputs 1 through 14 are capable of switching voltages up to 48VDC @ 1 Amp. Outputs 15 and 16 are capable of switching up to 250VAC @ 10 Amps. Both low and high power contact arrangements are shown below.

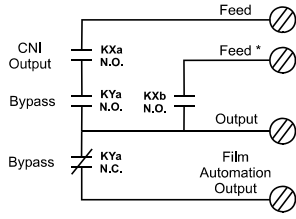

Low Power Relay Contacts

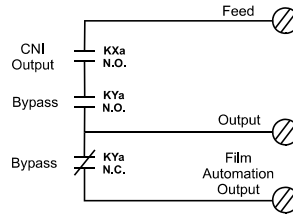

High Power Relay Contacts

**Bypass Mode**

Each output has a bypass control relay and jumper associated with it. The bypass control relays are controlled by either the bypass instruction or the bypass input allowing for manual and automatic activation. The purpose of bypass is to toggle control of the cinema equipment such as lights, masking, etc. between the film automation and the CNI. The film automation is in control when the bypass is "ON". The CNI-200 is in control when the bypass is "OFF". When the CNI power is off, the CNI defaults to bypass "ON". The bypass jumper controls whether the bypass relay is controlled by bypass 'mode' or not. Place the jumper block on positions 2 and 3 for bypass control. Place the jumper block on position 1 and 2 for a Form C contact that is not effected by bypass.

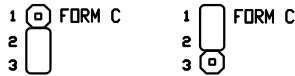

Bypass Jumper

**Termination Board Wiring**

**Outputs**

Outputs 1 through 14 have the same contact arrangement but can be wired differently depending on the method of control required. The wiring method will depend on the type of film automation and type of digital/film presentation desired.

Method 1: This simply parallels the normally open contacts of the film automation with the normally open contacts of the CNI. The film automation or the CNI can control the equipment anytime. The bypass jumper can be in either position.

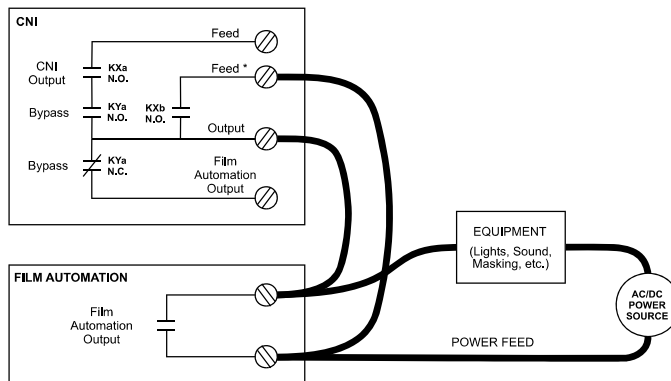

Method 2: This method uses the bypass control contacts to toggle control between the film automation and the CNI. The equipment can only be controlled by the 'active' unit. The film automation can control when bypass mode is on. The CNI can control when bypass mode is off. The bypass jumper must be on positions 2 and 3.

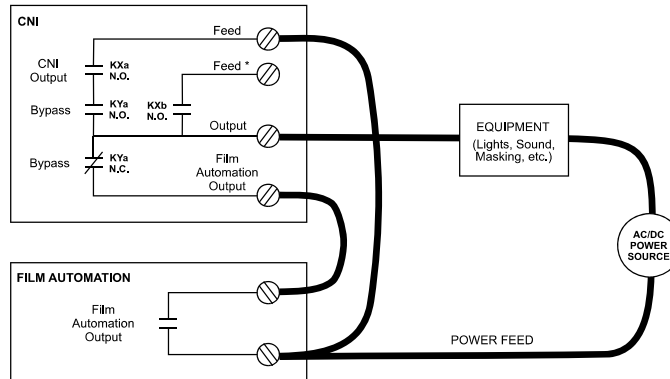

Method 3: This method allows the CNI to control anytime, but the film automation can only control when bypass mode is on. The bypass jumper must be on positions 2 and 3.

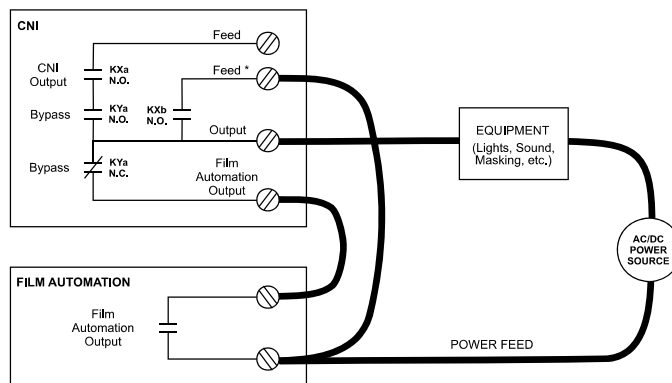

Method 4: This method can be used when an additional output is required for the digital cinema system. The bypass control relay could be disabled by moving the bypass jumper block to positions 1 and 2. This would create a FORM C contact giving a normally closed contact.

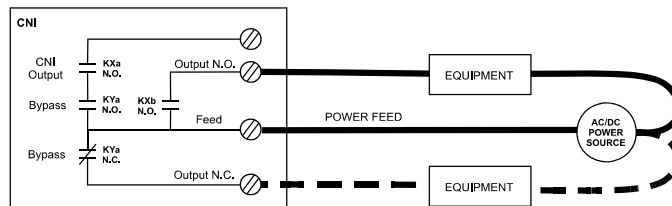

Note: The high power outputs do not support wiring method 3.

**Manual Switches**

Most film automation systems have manual override switches that can be used by the operator to manually control key booth and auditorium equipment such as the projector motor, screen masking and lighting. These manual switches are essential in the event of an automation failure. When the CNI is used in conjunction with a film automation the existing manual switches may not function during the digital presentation as expected. The CNI termination board provides quick connect tabs that can be used for manual override switches.

If wiring method 1 is employed, the manual switches on the existing film automation will function normally regardless of the bypass mode.

If wiring method 3 is implemented, the film automation switches will not work when the bypass mode is off. If feasible, the best solution may be to re-wire the film automation manual override switch as shown. Otherwise it will be necessary to add switches.

Method A: When method 4 is used to add a new output, a switch can be installed in the CNI system.

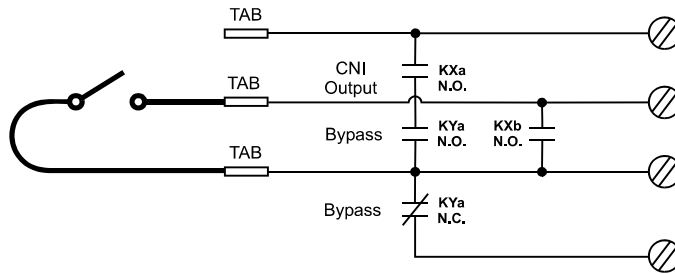

Method A: Manual switch wiring for Method 3 or 4 output wiring

Method B: If method 2 wiring is employed, the manual override switch should be installed as shown below.

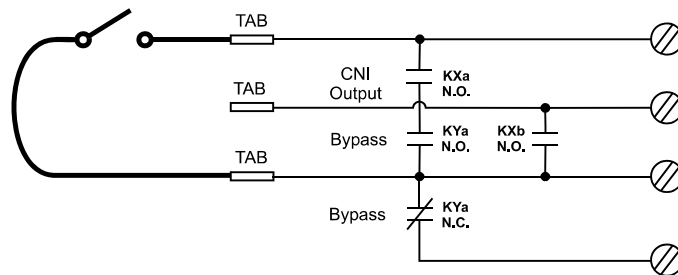

Method B: Manual switch wiring for Method 2 output wiring

## Inputs

The CNI termination board is equipped with 8 optically isolated digital inputs. Each input can accept AC or DC voltages in the range of 5 to 24 volts. The inputs can be individually configured for contact or voltage sense.

A typical voltage sense connection is shown below.

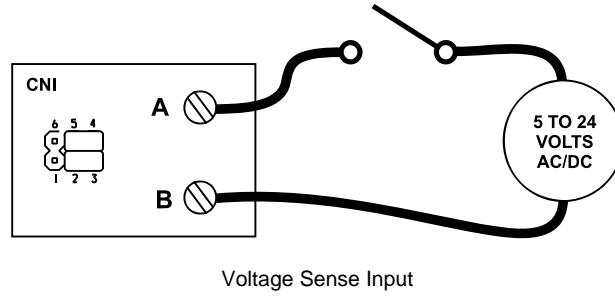

Using an on board power source, the inputs can be configured for contact sensing. Only a remote relay contact or switch is necessary to generate an input. A typical contact sense connection is shown below.

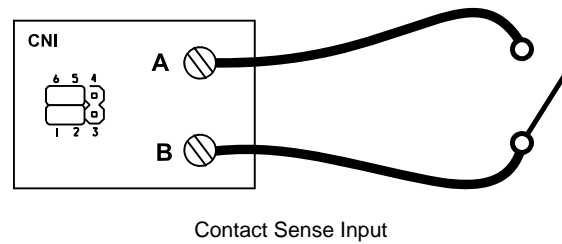

## Supervisory Setup

This section explains how to configure the CNI-200 Supervisory network settings and digital input/output.

### Network Setup

The Ethernet network parameters are displayed on page 16 of the Supervisory System Setup section. Press <Setup>< Super>< Setup System> Enter Password and goto page 16. The **Ethernet Mode**, **IP Address**, **Subnet Mask** and **Gateway IP Address** fields display the current values.

```

                Setup CNA System      Page 16
                  Ethernet
Ethernet Mode      Half Duplex
IP Address         192.168.  0.254
Subnet Mask        255.255.255.  0
Gateway IP Address  0.  0.  0.  0

**Any changes take effect next power-up.

```

### Ethernet Mode

The CNI can operate in half or full duplex mode. This setting will depend on your network. The default is Half Duplex. Select Half Duplex or Full Duplex with the Message keys.

### IP Address

The IP Address is displayed in the decimal-dot notation. Each CNI on the local network must have a unique IP Address. Change the address with the number keys.

### Subnet Mask

The Subnet mask is displayed in the decimal-dot notation. The Subnet Mask defines the number of bits taken from the IP address that are assigned for the host part. Change the Subnet Mask with the number keys.

**Standard IP Network Subnet Masks**

Network Class	Host Bits	Subnet Mask
A	24	255.0.0.0
B	16	255.255.0.0
C	8	255.255.255.0

### Gateway IP Address

The Gateway IP Address is displayed in the decimal-dot notation. The gateway address, or router, allows communication to other LAN segments. The gateway address should be the IP address of the router connected to the same LAN segment as the CNI. The gateway address must be within the local network. Change the address with the number keys.

## Digital I/O

The CNI digital I/O structure is flexible. Any input or output can be assigned to any CNI function or can be directly controlled by the client. The CNI supports two models of I/O boards and up to 2 boards at a time (board #1 and board #2).

Board #1 (LIN Id 17):

39440: 16 Outputs/8 Inputs OR 39490: 12 Outputs/8 Inputs

Board #2 (LIN Id 18):

39440: 16 Outputs/8 Inputs OR 39490: 12 Outputs/8 Inputs

## Input Functions

Inputs can be assigned any of the 10 functions in the table. All inputs can be read by the Digital Input command but inputs that are not assigned (blank) are not acted on by the CNI. These inputs are generally used by the digital client for a specific purpose. These functions are also supported by the CAI serial protocol. See the *Command Interface Protocol Specification* manual for details.

### Input Assignments

Name	Description
<<Blank>>	Not acted on by the CNI. Can be use as general purpose input.
Digital 1 Cue	Auxiliary Cue Input from digital system 1 (Always active)
Digital 1 Fault	Major Fault input from digital system 1
Digital 1 Stop	Stop Input from digital system 1
Digital 1 Start	Start Input from digital system 1
Digital 2 Cue	Auxiliary Cue Input from digital system 2 (Always active)
Digital 2 Fault	Major Fault input from digital system 2
Digital 2 Stop	Stop Input from digital system 2
Digital 2 Start	Start Input from digital system 2
Bypass	De-activates the Bypass Control Relays on 39440 Termination Board.

The Digital Cue is used by the client to advance the CNI program, just as the film cue is used by the film automation system. The CNI-200 currently supports up to 20 cues per program.

The Digital Fault is defined as a 'major fault' in which the CNI will stop the show, drive the outputs to their defined 'fault-to' states and sound the alarm. This would generally be used by the digital client in the event of a digital system error or fault. The alarm would notify the operator that manual intervention is required.

The Digital Start is used to start the show. This is the same as pushing the start key on the CNI-200 front panel. The Digital Stop is used to stop the show. This is the same as pushing the stop key on the CNI-200 front panel.

The Bypass is a special function that is used to active/de-active the bypass control relays on the 39440 termination board. The Bypass input is useful as a hard-wired switch available to the operator for manual control of the bypass function. This would allow the operator to conveniently switch control to the film automation overriding the CNI program without powering down the CNI.



**Output Functions**

The outputs of the boards can be assigned any of the 40 functions in the table. Serial output commands have exclusive control over the outputs that are not assigned (blank) and are not affected by internal CNI logic. Other assigned outputs are controlled exclusively by the CNI program or status flags.

**Output Assignments**

Name	Description	Name	Description
<<Blank>>	Controlled by External Serial Device (Ethernet/RS-232)	Mask Flat	Controlled by <i>Format</i> or <i>Masking</i> program instructions
DP1 Pwr Off	Controlled by <i>Digital Projector 1 Power Off</i> program instruction	Mask Scope	Controlled by <i>Format</i> or <i>Masking</i> program instructions
DP1 Pwr On	Controlled by <i>Digital Projector 1 Power On</i> program instruction	Mask Special	Controlled by <i>Format</i> or <i>Masking</i> program instructions
DP1 Vid Off	Controlled by <i>Digital Projector 1 Video Off</i> program instruction	Lens Flat	Controlled by <i>Format</i> or <i>Lens</i> program instructions
DP1 Vid On	Controlled by <i>Digital Projector 1 Video On</i> program instruction	Lens Scope	Controlled by <i>Format</i> or <i>Lens</i> program instructions
DP2 Pwr Off	Controlled by <i>Digital Projector 2 Power Off</i> program instruction	Lens Special	Controlled by <i>Format</i> or <i>Lens</i> program instructions
DP2 Pwr On	Controlled by <i>Digital Projector 2 Power On</i> program instruction	Slide Projector	Controlled by <i>Slide Projector</i> program instructions
DP2 Vid Off	Controlled by <i>Digital Projector 2 Video Off</i> program instruction	Sound Aux 1	Controlled by <i>Format</i> or <i>Sound</i> program instructions
DP2 Vid On	Controlled by <i>Digital Projector 2 Video On</i> program instruction	Sound Aux 2	Controlled by <i>Format</i> or <i>Sound</i> program instructions
In Progress	Controlled by CNI's <i>In Progress</i> Flag	Sound Digital 1	Controlled by <i>Format</i> or <i>Sound</i> program instructions
Fault	Controlled by CNI's <i>Major Fault</i> Flag	Sound Digital 2	Controlled by <i>Format</i> or <i>Sound</i> program instructions
Fire Stop	Controlled by CNI's <i>Fire Stop</i> Flag	Sound Mono	Controlled by <i>Format</i> or <i>Sound</i> program instructions
H. Lights Down	Controlled by <i>House Lights Down</i> program instruction	Sound Mute	Controlled by <i>Format</i> or <i>Sound</i> program instructions
H. Lights Mid 1	Controlled by <i>House Lights Mid 1</i> program instruction	Sound Non-Sync	Controlled by <i>Format</i> or <i>Sound</i> program instructions
H. Lights Mid 2	Controlled by <i>House Lights Mid 2</i> program instruction	Sound SR	Controlled by <i>Format</i> or <i>Sound</i> program instructions
H. Lights Up	Controlled by <i>House Lights Up</i> program instruction	Sound SVA	Controlled by <i>Format</i> or <i>Sound</i> program instructions
S. Lights Down	Controlled by <i>Stage Lights Down</i> program instruction	Out 1	Controlled by <i>Aux Out</i> program instruction
S. Lights Up	Controlled by <i>Stage Lights Up</i> program instruction	Out 2	Controlled by <i>Aux Out</i> program instruction
Curtain Open	Controlled by <i>Curtain Open</i> program instruction	Out 3	Controlled by <i>Aux Out</i> program instruction
Curtain Close	Controlled by <i>Curtain Close</i> program instruction	Out 4	Controlled by <i>Aux Out</i> program instruction

**Supervisory Input/Output Setup Screens**

Press <Menu><Set-up><Set-up Super><Set-up System> and enter the password (The default password is **3141**) to access the system Supervisory.

Page 3 and 4 of the Supervisory allow you to configure the behavior of standard output functions.

Setup System		Page 3	
Output	Contact	Power-up	Fault-to
Lens	Pulsed	Flat	Flat
Masking	Pulsed	Flat	Flat
Sound	Pulsed	Non-Sync	Non-Sync
H. Lights	Pulsed	Up	Up
S. Lights	Pulsed	Up	Up
Curtain	Pulsed	No-op	No-op
Slide Proj	Maint.	No-op	No-op
Out 1	Pulsed	No-op	No-op
Out 2	Pulsed	No-op	No-op
Out 3	Maint.	No-op	No-op
Out 4	Maint.	No-op	No-op

Setup System		Page 4	
Output	Power-up	Fault-to	
DP1 Power	Off	Off	
DP1 Video	Off	Off	
DP2 Power	Off	Off	
DP2 Video	Off	Off	

Page 5 allows any output function to be controlled by the Aux Out Instruction. Page 6 and 7 allows any output function to be assigned to any of the 39440/39490 termination board relays outputs.

Setup System		Page 5	
Output 1 Controls:	None		
Output 2 Controls:	None		
Output 3 Controls:	None		
Output 4 Controls:	None		

Setup System		Page 6	
Board 1: 39440/39490 #1			
Out	Controlled by	Contact	
1		Pulsed	
2		Pulsed	
3		Pulsed	
4		Pulsed	
5		Pulsed	
6		Pulsed	
7		Pulsed	
8		Pulsed	
9		Pulsed	
10		Pulsed	
11		Pulsed	
12		Pulsed	

Page 8 allows any input function to be assigned to any 39440/39490 termination board input.

Setup System		Page 7	
Board 1: 39440/39490 #1			
Out	Controlled by	Contact	
13		Pulsed	
14		Pulsed	
15		Pulsed	
16		Pulsed	

Setup System		Page 8	
Board 1: 39440/39490 #1			
In	Connected to		
1			
2			
3			
4			
5			
6			
7			

Pages 9, 10 and 11 are used to setup board #2 if a second board is installed.

## Manual Control Screen

Press *<Menu><Manual Control>* to access the manual control screen. This screen displays the current state of most functions. It also allows the operator to override any of these functions. This is particularly useful for testing and troubleshooting, but can also be used to correct for programming errors. Although this allows the operator to override the current state of a function, be aware that a power cycle, fault or program instruction can drive the function to a new state.

The active state is displayed in reverse video.

Manual Control			
Volume	Sound	Lens	H. Lights
- 50.0dB	<b>Non-Sync</b>	Flat	<b>Up</b>
<b>&gt; Mute</b>	Mono	<b>Scope</b>	Mid 1
	SVA	Special	Mid 2
Aux Out	SR		Down
<b>Out 1</b>	Dig 1	Masking	
Out 2	Aux 1	Flat	S. Lights
Out 3	Dig 2	<b>Scope</b>	<b>Up</b>
Out 4	Aux 2	Special	Down
Proj 1	Proj 2	Curtain	Slide Proj
DP1 Pwr	DP2 Pwr	<b>Open</b>	On
DP1 Vid	DP2 Vid	Close	
			Bypass
			On

## CNI-200 Program Editor

There are currently 36 instructions available to build programs. A program is a series of instructions that are executed as they are encountered. The Wait Cue instruction is a special instruction that causes the program to wait for a 'cue' event before continuing. Most instructions have an associated delay time which allow time-delayed execution. The CNI can store up to nine programs.

Press <Menu><Set-up Program> and enter the password to access the editor (The default password is **3141**). Use the Insert/Edit, Cursor Up/Down and Enter keys to insert instructions into the program editor. Use the Number, Clear and Cursor keys to edit delay times, etc. See the *eCNA-200 Setup and Operations* manual for a detailed description of each instruction.

### Program Instructions

No.	Instruction	Parameters / Delay Time
0	<< blank >>	n/a
1	House Lights Up	<b>dd:dd</b> <b>dd:dd</b> = 0:00 to 59:59 minutes:seconds
2	House Lights Down	<b>dd:dd</b> <b>dd:dd</b> = 0:00 to 59:59 minutes:seconds
3	House Lights Mid 1	<b>dd:dd</b> <b>dd:dd</b> = 0:00 to 59:59 minutes:seconds
4	House Lights Mid 2	<b>dd:dd</b> <b>dd:dd</b> = 0:00 to 59:59 minutes:seconds
5	House Lights None	<b>dd:dd</b> <b>dd:dd</b> = 0:00 to 59:59 minutes:seconds
6	Stage Lights Up	<b>dd:dd</b> <b>dd:dd</b> = 0:00 to 59:59 minutes:seconds
7	Stage Lights Down	<b>dd:dd</b> <b>dd:dd</b> = 0:00 to 59:59 minutes:seconds
8	Stage Lights None	<b>dd:dd</b> <b>dd:dd</b> = 0:00 to 59:59 minutes:seconds
9	Curtain Open	<b>dd:dd</b> <b>dd:dd</b> = 0:00 to 59:59 minutes:seconds
10	Curtain Close	<b>dd:dd</b> <b>dd:dd</b> = 0:00 to 59:59 minutes:seconds
11	Curtain None	<b>dd:dd</b> <b>dd:dd</b> = 0:00 to 59:59 minutes:seconds
12	Curtain Call	<b>dd:dd</b> <b>dd:dd</b> = 0:00 to 59:59 minutes:seconds
13	Curtain Close Early	<b>dd:dd</b> <b>dd:dd</b> = 0:00 to 59:59 minutes:seconds
14	Slide Projector On	<b>dd:dd</b> <b>dd:dd</b> = 0:00 to 59:59 minutes:seconds
15	Slide Projector Off	<b>dd:dd</b> <b>dd:dd</b> = 0:00 to 59:59 minutes:seconds
16	Cue Factor	<b>.ddd</b> <b>.ddd</b> = .000 to .999
17	Format <b>d: m1 m2</b>	<b>d</b> = 1 to 9 <b>m1</b> = Non-Sync; Mono; SVA; SR; Digital 1; Aux 1; Digital 2; Aux 2 <b>m2</b> = Flat; Scope; Special
18	Wait Cue <b>d</b>	<b>d</b> = 0 to 20
19	Shutdown Delay	<b>dd:dd</b> <b>dd:dd</b> = 0:00 to 59:59 minutes:seconds
20	Wait	<b>dd:dd</b> <b>dd:dd</b> = 0:00 to 99:99 minutes:seconds
21	Changeover Open	<b>dd:dd</b> <b>dd:dd</b> = 0:00 to 59:59 minutes:seconds
22	Changeover Close	<b>dd:dd</b> <b>dd:dd</b> = 0:00 to 59:59 minutes:seconds
23	Changeover None	<b>dd:dd</b> <b>dd:dd</b> = 0:00 to 59:59 minutes:seconds
24	Changeover Auto	<b>dd:dd</b> <b>dd:dd</b> = 0:00 to 59:59 minutes:seconds
25	Projector Motor/Lamp On	n/a
26	Projector Motor/Lamp Off	n/a
27	Intermission Wait	<b>dd:dd</b> <b>dd:dd</b> = 0:00 to 99:99 minutes:seconds
28	Aux <b>m1 m2</b>	<b>m1</b> = Out 1, Out 2, Out 3, Out 4 <b>m2</b> = On, Off <b>dd:dd</b> = 0:00 to 99:99 minutes:seconds
29	Volume <b>d1</b> dB Fade Time <b>d2</b>	<b>d1</b> = -50.0 to +10.0 dB <b>d2</b> = 0 to 10 seconds <b>dd:dd</b> = 0:00 to 99:99 minutes:seconds
30	<b>m1</b> Lights <b>m2</b>	<b>m1</b> = House; Stage; Zone 3 to Zone 16 <b>m2</b> = Up; Down; Mid 1; Mid 2 <b>dd:dd</b> = 0:00 to 59:59 minutes:seconds
31	Sound: <b>m</b>	<b>m</b> = Non-Sync; Mono; SVA; SR; Digital 1; Aux 1; Digital 2; Aux 2
32	Lens/Masking: <b>m</b>	<b>m</b> = Flat; Scope; Special
33	Lens: <b>m</b>	<b>m</b> = Flat; Scope; Special
34	Masking: <b>m</b>	<b>m</b> = Flat; Scope; Special
35	Projector: <b>m</b>	<b>m</b> = Film Off; Film On; Changeover Close; Changeover Open; Digital 1 Pwr Off; Digital 1 Pwr On; Digital 1 Vid Off; Digital 1 Vid On; Digital 2 Pwr Off; Digital 2 Pwr On; Digital 2 Vid Off; Digital 2 Vid On <b>dd:dd</b> = 0:00 to 59:59 minutes:seconds
36	Bypass: <b>m</b>	<b>m</b> = Off; On; No-op <b>dd:dd</b> = 0:00 to 59:59 minutes:seconds

**d** = decimal number; **m** = message

## Application Example

This section describes how the CNI-200 could be connected and programmed to work with the Strong Model SPA-7 automation system. The SPA-7 Cinema Automation sold by Strong International from 1992 to 1997 is a typical cinema automation with some programmability. It is a single 3-cue system. This means that a single outboard cue is required to be placed on the film in which the cue advances the program to the next state where the appropriate outputs are activated. Below is a timing diagram that describes the normal operation of the SPA-7. The outputs shown in the timing diagram are dry relay contacts. Some can be programmed for pulsed or maintained.

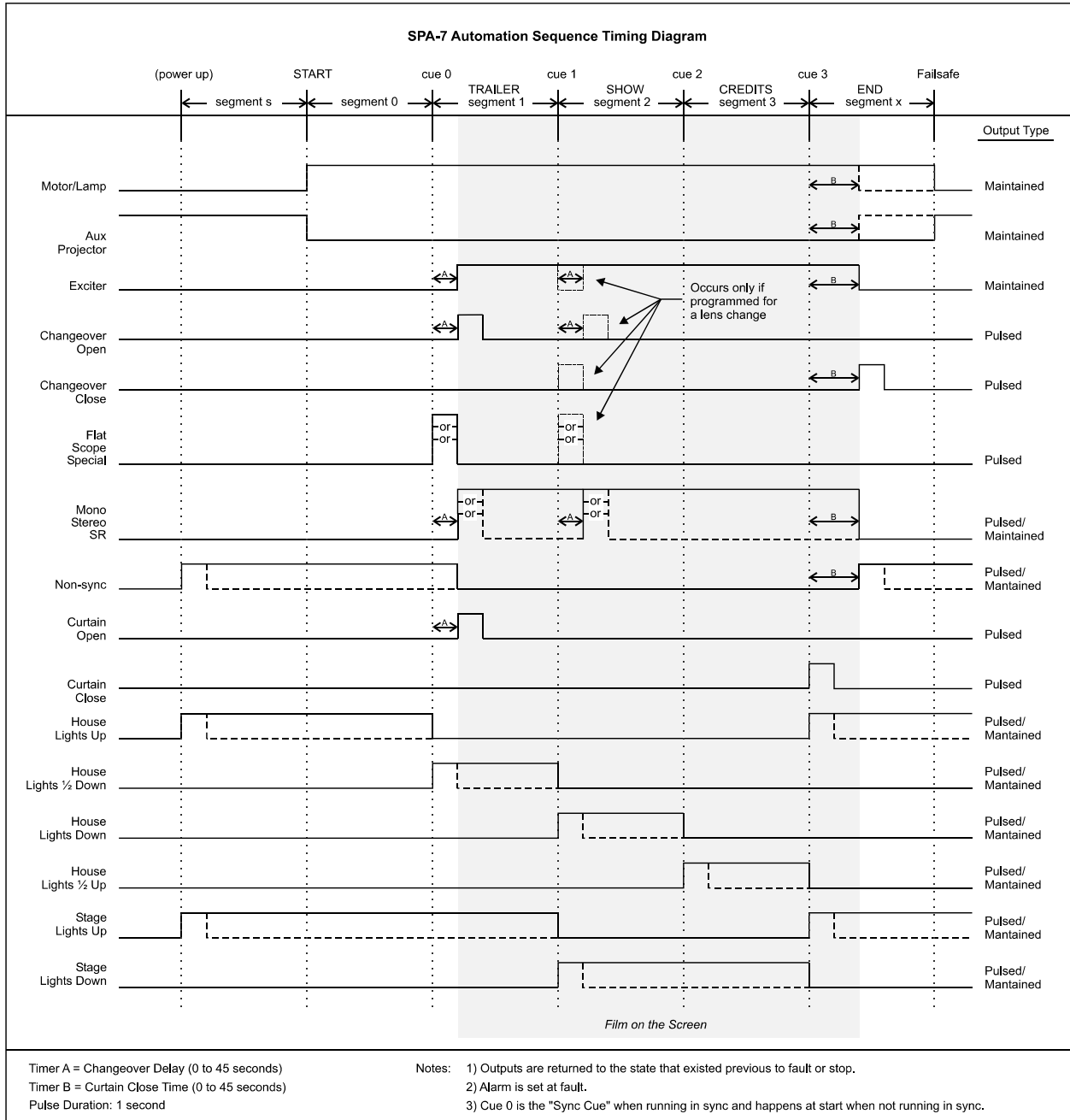

### SPA-7 to CNI-200 Wiring

The following wiring diagrams show one possible way to wire the CNI-200 to the SPA-7 film automation. There are many ways this could be accomplished, depending on the requirements of the digital and film presentations. This is an example of a more flexible scheme allowing any mixture of digital and/or film content.

CNI-200 Cinema Network Interface

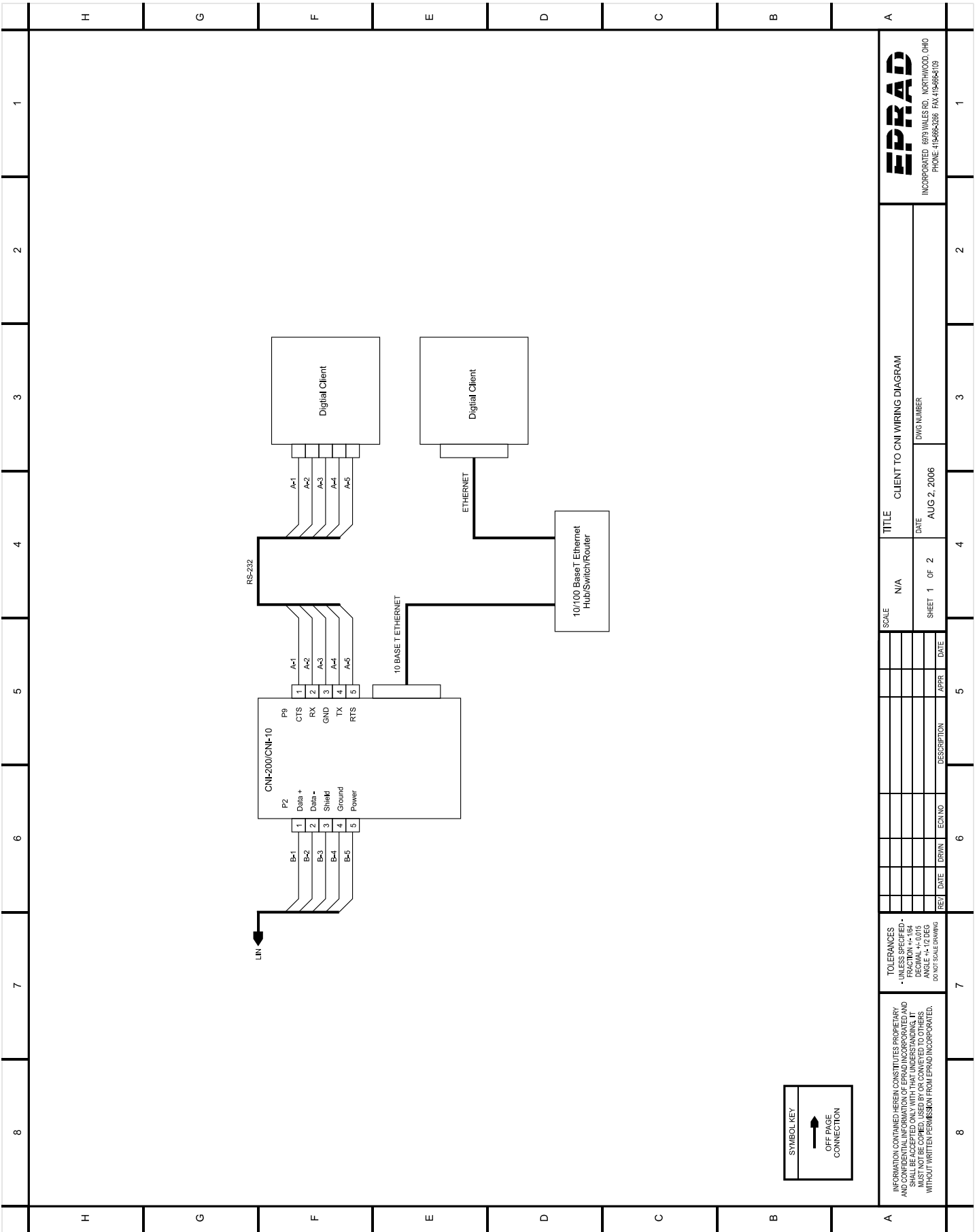

SYMBOL KEY  
 OFF PAGE CONNECTION

**EP RAD**  
 INCORPORATED 6929 WALKER RD. NORTHWOOD, OHIO  
 PHONE: 419-663-2266 FAX: 419-663-1103

REV	DATE	DRWN	ECN NO	DESCRIPTION	APPR	DATE

**TOLERANCES**  
 • UNLESS SPECIFIED -  
 FRACTION 1/164  
 DECIMAL +- .0015  
 HOLE SIZE  
 DO NOT SCALE DRAWING

INFORMATION CONTAINED HEREIN CONSTITUTES PROPRIETARY AND CONFIDENTIAL INFORMATION OF EP RAD, INC. AND SHALL BE ACCEPTED ONLY WITH THAT UNDERSTANDING. IT MUST NOT BE COPIED, USED BY OR CONVEYED TO OTHERS WITHOUT WRITTEN PERMISSION FROM EP RAD, INCORPORATED.

**TITLE** CLIENT TO CNI WIRING DIAGRAM  
**SCALE** N/A  
**DATE** AUG 2, 2006  
**DWG NUMBER**  
**SHEET 1 OF 2**

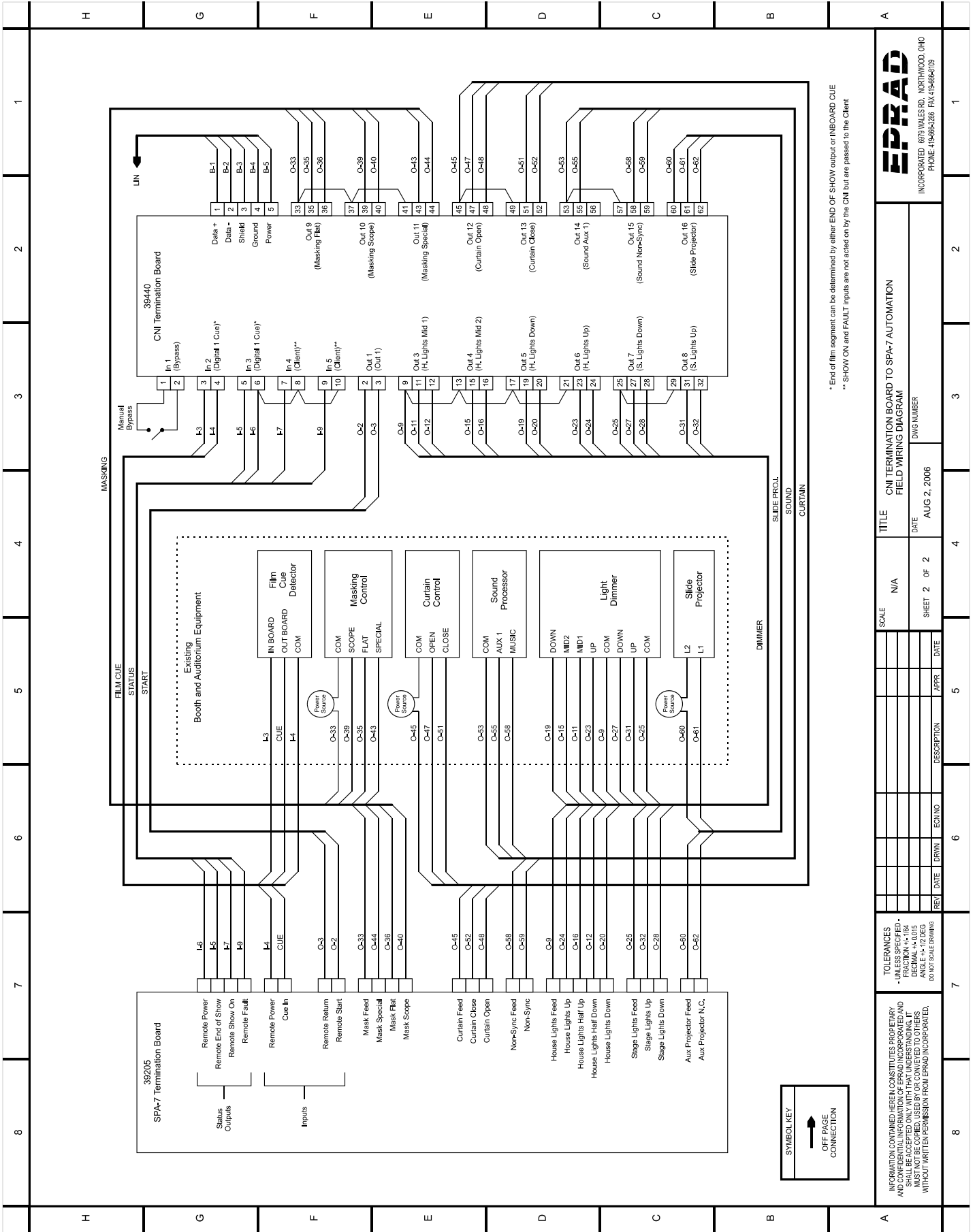

\* End of film segment can be determined by either END OF SHOW output or INBOARD CUE  
 \*\* SHOW ON and FAULT inputs are not acted on by the CNI but are passed to the Client



INCORPORATED 8670 WALES RD. NORTHWOOD, OHIO  
 PHONE: 419-665-2338 FAX: 419-668-8103

TITLE	CNI TERMINATION BOARD TO SPA-7 AUTOMATION FIELD WIRING DIAGRAM
DATE	AUG 2, 2006
DWG NUMBER	

SCALE	N/A
SHEET	2 OF 2

REV	DATE	BY	CHKD	DESCRIPTION	APPR	DATE

TOLERANCES  
 \* UNLESS SPECIFIED -  
 FRACTION  $\pm$  .004  
 DECIMAL  $\pm$  .005  
 ANGLE  $\pm$  .02 DEG  
 DO NOT SCALE DRAWING

INFORMATION CONTAINED HEREIN CONSTITUTES PROPRIETARY AND CONFIDENTIAL INFORMATION OF EPRAD INCORPORATED AND SHALL BE ACCEPTED ONLY WITH THAT UNDERSTANDING. IT MUST NOT BE COPIED, USED BY OR CONVEYED TO OTHERS WITHOUT WRITTEN PERMISSION FROM EPRAD INCORPORATED.

Page 1 of the wiring diagram shows how the digital client is connected to the CNI-200. This could be either an RS-232 serial connection or Ethernet. The protocol is identical either way.

Page 2 shows the how the CNI is connected to the SPA-7. Most of the outputs are wired using Method 2 as described in a previous section. This is required for some outputs due to the SPA-7's behavior at the end of the film show. For example, after the end of show cue the sequence of events are as follows:

Curtain = CLOSE  
 House Lights = UP  
 Stage Lights = UP  
*(Timer B times out)*  
 Slide Projector = ON  
 Sound = NON-SYNC

Note: If there is not a curtain, Timer B is most likely set to 0 seconds.

If you wanted a Digital Show to follow the Film Show, you would not want the slide projector on the screen, auditorium lights full up or non-sync music playing. Therefore, in order to prevent this, the CNI-200 would need to take control of those outputs before the end of show cue. This could be detected from an inboard cue by the film cue detector. If there is a start-up time required by the digital projector, the inboard cue would be placed on the film at the appropriate location previous to the SPA-7 'End of Show' cue equal the digital start up delay time. This would provide for a smooth transition from film to digital. The SPA-7 would end the film portion of the presentation as it normally does. The CNI-200 program will then control the lights, masking, curtain, etc. for the digital portion of the presentation.

**Digital I/O Setup**

Configure the CNI-200 inputs and outputs on page 6 through 8 of the Supervisory. This configuration assumes the digital client has a serial connection to the CNI-200.

Setup System		Page 6
Board 1: 39440/39490 #1		
Out Controlled by	Contact	
1 Out 1	Pulsed	
2	Pulsed	
3 H. Lights Mid 1	Pulsed	
4 H. Lights Mid 2	Pulsed	
5 H. Lights Down	Pulsed	
6 H. Lights Up	Pulsed	
7 S. Lights Down	Pulsed	
8 S. Lights Up	Pulsed	
9 Mask Flat	Pulsed	
10 Mask Scope	Pulsed	
11 Mask Special	Pulsed	
12 Curtain Open	Pulsed	

Setup System		Page 7
Board 1: 39440/39490 #1		
Out Controlled by	Contact	
13 Curtain Close	Pulsed	
14 Sound Aux 1	Pulsed	
15 Non-Sync	Pulsed	
16 Slide Projector Maint.		

Setup System		Page 8
Board 1: 39440/39490 #1		
In Connected to		
1 Bypass		
2 Digital 1 Cue		
3 Digital 1 Cue		
4		
5		
6		
7		



**CNI Program**

This Program controls the auditorium and booth equipment for the digital portions of the presentation and passes control to the film automation for the film portion of the presentation. The digital client only needs to 'cue' the CNI to advance the program to the next 'state' in which a new event sequence is initiated. This program starts with a digital pre-show, switches to film advertisements and switches back to digital for a feature movie.

This program assumes:

1. There is a one minute start-up time for the Digital Projector.
2. There are curtains and a 'curtain call' between the Film Advertisements and Digital Feature.
4. The curtain close time is about 8 seconds.
3. The Slide Projector is on between shows.

The show is started by the digital client...

1-	1	Projector:Film	Off	0:00	Keep Projector Motor flag off. Required for backward compatibility.
1-	2	Bypass: Off		0:00	1 Make sure CNI-200 is in control for digital pre-show
1-	3	Projector:Digital 1 Pwr On		0:00	Turn digital projector (for warm-up)
1-	4	Masking: Flat			Set up screen masking for digital pre-show
1-	5	--- Wait ---		1:00	Wait for 1 minute (Digital system start up time)
1-	6	Projector:Digital 1 Vid On		0:00	2 Digital Pre-show on the screen
1-	7	Slide Projector Off		0:00	
1-	8	House Lights Mid 1		0:00	
1-	9	Stage Lights Down		0:00	
1-	10	Sound: Aux 1			Select sound for digital system
1-	11	--- Wait Cue 1 ---			Wait for End of Pre-show cue from digital client
1-	12	Bypass: On		0:00	3 Switch control to SPA-7
1-	13	Aux Out 1 On		0:00	Start SPA-7
1-	14	--- Wait ---		0:01	
1-	15	Aux Out 1 Off		0:00	
1-	16	--- Wait ---		0:04	Wait for SPA-7 Changeover Delay
1-	17	Projector:Digital 1 Vid Off		0:00	4 Digital video off the screen. Film on the screen.
1-	18	Projector:Digital 1 Pwr Off		0:00	
1-	19	--- Wait Cue 2 ---			Wait for the inboard cue (placed 1 minute (90 feet) before End of Show cue)
1-	20	Bypass: Off		0:00	5 Switch Control back to CNI-200
1-	21	Projector:Digital 1 Pwr On		0:00	Turn digital projector (for warm-up)
1-	22	Curtain Close		0:50	6 Begin to close curtain 10 seconds before End of Show cue
1-	23	--- Wait Cue 3 ---			Wait for SPA-7 End of Show Cue
1-	24	Projector:Digital 1 Vid On		0:00	7 Digital Feature on the screen
1-	25	Curtain Open		0:00	
1-	26	Masking: Scope		0:00	
1-	27	Sound: Aux 1			Select sound for digital system
1-	28	House Lights Down		0:00	
1-	29	--- Wait Cue 4 ---			Wait for Credits cue from digital client
1-	30	House Lights Mid 2		0:00	8 Raise lights to half level for credits
1-	31	--- Wait Cue 5 ---			Wait for End of Show cue from digital client
1-	32	Stage Lights Up		0:00	9 Intermission
1-	33	House Lights Up		0:00	
1-	34	Slide Projector On		0:00	
1-	35	Sound: Non-Sync		0:00	
1-	36	Projector:Digital 1 Vid Off		0:00	
1-	37	Projector:Digital 1 Pwr Off		0:00	

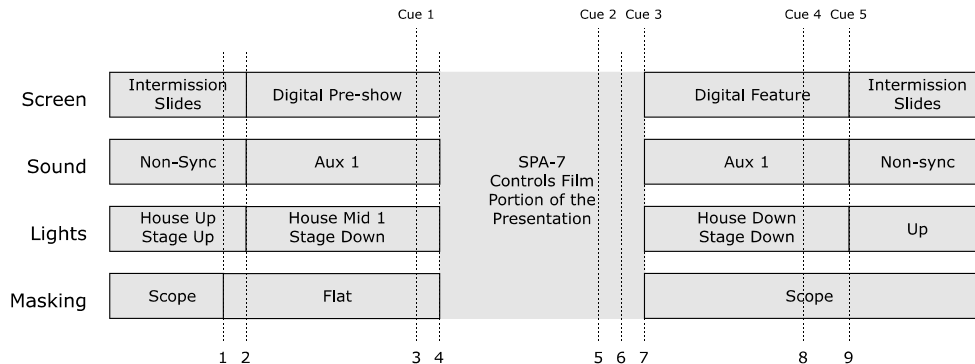

Cues from Digital Client = Cue 1, 4 and 5; Cues from SPA-7 = Cue 2 and 3

**Manual Override Switches**

The manual override switches on the SPA-7 are in parallel with the output relay contacts. Therefore, when the Bypass is off (CNI-200 in control), the manual switches will not work from the SPA-7 control panel. The easiest way to solve this problem is to add manual switches to the CNI-200 system. Wire the manual switches to the CNI termination board using method B. This would allow the manual controls to operate in both bypass modes. Use the switch identification labels provided to label the manual override switches.

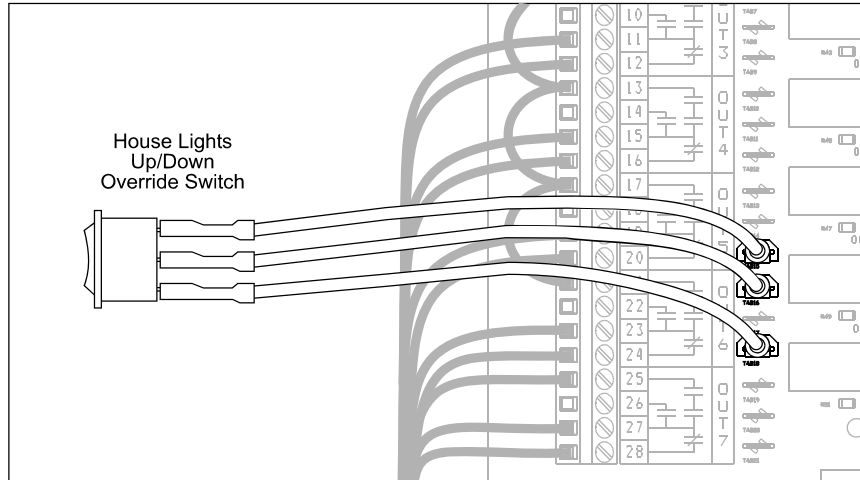

Manual Switch Wiring Example