

# Strong eCNA-100 Automation

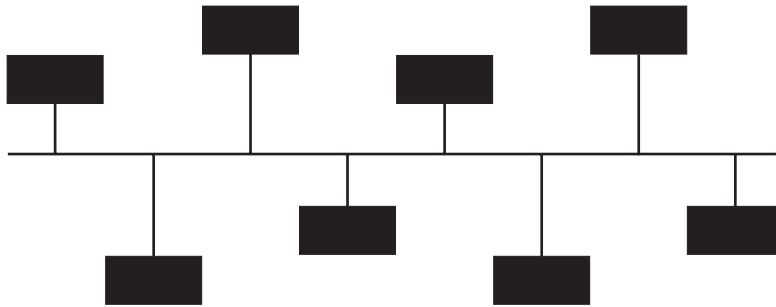

## Setup and Operation Manual



Revision 1.02  
March 2006



# **eCNA-100**

## **Setup and Operation Manual**

### **PR012 Revision 1.02**

---

This manual covers the setup and operation of the CNA Cinema Automation..

Optional CineNet and related equipment is covered in the following product reference manuals:

- PR001 CNA Installation Manual
- PR002 CNA-200 Setup and Operation Manual
- PR003 CNA-150 Setup and Operation Manual
- PR004 CNA-100 Setup and Operation Manual
- PR005 QDC-400 Installation and Setup Manual
- PR006 ACP-50 Installation and Setup Manual
- PR007 RVC-5 Installation and Setup Manual
- PR008 PCI-64 Gateway Interface Installation
- PR009 CineNet Host Software
- PR010 RCM-10/RSM-10/RSM-20 Installation and Operation Manual
- PR011 Strong Dimmer Installation, Setup, and Operation Manual
- PR012 eCNA-100 Automation Manual
- PR013 eCNA-150 Automation Manual
- PR014 eCNA-200 Automation Manual
- PR016 Strong FP350 Installation and Operation Manual
- PR017 Eprad FP350 Installation and Operation Manual
- PR018 Paging system Setup and Installation Manual
- PR019 VNC Setup and Operation Manual
- PR020 CineSuite Installation and Operation Manual

---

### **Warranty**

CineNet automation products, sold by STRONG INTERNATIONAL, are warranted against defects in materials and workmanship for one year from the date of purchase. There are no other express or implied warranties and no warranty of merchantability or fitness for a particular purpose.

During the warranty period, STRONG INTERNATIONAL will repair or, at its option, replace components that prove to be defective, provided the unit is shipped prepaid to the manufacturer directly or via an authorized distributor. Not covered by this warranty are defects caused by modification, misuse or accidents and any further damage caused by inadequate packing for service return.

STRONG INTERNATIONAL's obligation is restricted to the repair or replacement of defective parts and under no circumstances will STRONG INTERNATIONAL be liable for any other damage, either direct or consequential.

---

Information in this document is subject to change without notice. No part of this document may be reproduced or transmitted in any form or by any means, electronic or mechanical, for any purpose, without the express written permission of STRONG INTERNATIONAL.

© 1997 - 2005 STRONG INTERNATIONAL. All rights reserved...



## Table of Contents:

<b>Introduction</b> .....	1
<b>Section 1</b>	
System Overview .....	2
Product Description .....	3
Local I/O Network (LIN) .....	3
Local Synchronous Network (LSN) .....	3
System Components .....	3
Control Panel (Operator Interface) .....	3
Booth Termination Panel .....	7
Single Termination Panel .....	7
Configuring the System .....	8
Switch Definitions .....	10
RS-232 Based IP Configuration .....	14
HTML IP Configuration .....	16
Interface Hardware .....	18
TCP/ IP Networking Overview .....	20
Alarm Loudness .....	22
Status LEDs .....	22
<b>Section 2</b>	
Setup .....	23
Programming the eCNA-100 .....	23
Intermission and Curtain Call Keys .....	24
Operating the eCNA-100 .....	25
Soft Manual Overrides .....	26
Synchronous Operation .....	26
System Status Messages .....	26
Fault Condition Messages .....	26
Memory Faults .....	27
Run-Time Faults .....	27
Sync Interlock Failsafe Fault .....	28
Power Up Messages .....	29
<b>Addendum</b>	
Software Changes .....	36
Supervisory Defaults Explained .....	39
The States of “No-Op” and “None” .....	40
<b>Index</b> .....	42
eCNA-100 Major replacement parts .....	44



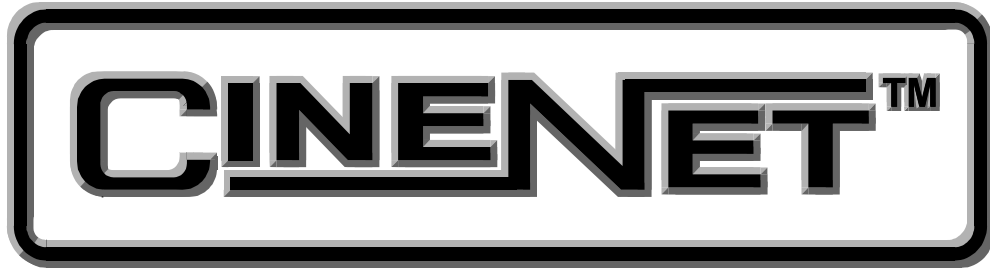

## An Introduction to **THE CINENET™ SYSTEM**

Strong International's CINENET™ is an automation and control network designed specifically for the Motion Picture Theatre Industry. CINENET™ provides a low cost connection to various control and I/O devices in the projection booth, auditorium, and throughout the theatre complex. CINENET™ is divided into multiple network layers: The Local Synchronous Network (LSN) is a complex-wide data network that provides advanced synchronous projector control, user selected data transfer and real-time remote automation status. The Local I/O Network (LIN) is designed to provide remote I/O control for each screen in a complex. A standard RJ45 Ethernet connection provides operation over TCP/IP for interface with various devices. The CINENET™ network offers many advantages over point-to-point wiring such as reduced installation costs, reduced wiring errors and high noise immunity. CINENET™ also allows management to program and access real-time status of all auditoriums in the theatre complex from a central location using a personal computer. Strong will continue to develop new CINENET™ products that will provide the control and flexibility the theatre industry demands.

## Section 1

### SYSTEM OVERVIEW

The eCNA-100<sup>®</sup> Cinema Network Automation is a CINENET<sup>™</sup> compatible automation system specifically designed for the Motion Picture Theatre industry. The system is modular in design, consisting of the operator interface and system peripherals. The Main Computer and each peripheral device is defined by its common functions and locations in the booth. The devices within the system communicate with each other on a serial communications link. Automation systems and remote stations distributed throughout the booth and other areas of the multiplex communicate on a second serial communications link.

The eCNA-100 operator interface is user friendly and self-intuitive. Once some basic rules are learned you will be programming and running basic programs in less than an hour.

To enhance the operation of the eCNA-100 and provide a higher level of control, the CINENET<sup>™</sup> Gateway PC Card and Host software is available. This product will provide a PC interface to the eCNA-100 automations. The Host PC and software will allow management to access programming, data logging and diagnostic information from all systems connected to the network. Access to data and system upgrade software will also be available via the modem/Internet. This model also provides the user with a RJ45 Ethernet connection and runs the TCP/IP protocol. This interface will facilitate the CNA's interaction with other devices in the projection booth and is a convenient way to configure and monitor the automation.

This manual provides the installer and user with the necessary information to install, setup and operate the eCNA-100 automation system. The installer is encouraged to read all sections of the manual before proceeding with the installation. If while installing or operating the eCNA-100 automation you find any part of the manual to be unclear or incorrect, please let us know. Call STRONG INTERNATIONAL at (800)-424-1215 if help or additional information is required.



## Product Description

The eCNA-100 Cinema Network Automation System is a microprocessor based computer automation designed to automate all aspects of the theatre presentation. The major features of the eCNA-100 are listed in this manual.

### Local I/O Network (LIN)

Each system component is connected to the network and communicates via a five wire cable. This cable provides the serial communications as well as power to the termination panels. This is called the "Local I/O Network" or "LIN". The standard devices that make up the system are the:

1. Console Termination Panel
2. Booth Termination Panel
3. eCNA-100 Control Panel

The eCNA-100 Automation Control Panel contains the Main or Master Computer of the system and each I/O device is connected to it via a serial communications link. The devices are connected in a "daisy-chain" method and can then be distributed within the booth according to their logical location.

### Local Synchronous Network (LSN)

The "Local Synchronous Network" is a two-wire data link that will support CNA-100/150, eCNA-100/150, eCNA-200 and CNA-200 Automations, remote stations, synchronous communications for interlock, network copy functions and a Host PC. The automation systems are connected together in a "daisy-chain" configuration, which allows the transmission line to continue from one unit to the next.

## System Components

The standard components that make up the automation system LIN are described in the following sections.

### Control Panel (Operator Interface)

The automation controller and front panel interface is a self-contained unit that can either be surface mounted to the booth wall or can be mounted in a standard 19" rack. The unit will house the main CPU, the front panel interface and the power supply for local and remote power for the Local I/O Network.

Communications to the local I/O devices and other remote CNA systems is accomplished via two serial ports on the Main CPU:

*The Local I/O Network (LIN) Com Port* - This is the interface for the Local I/O Network that will support the Main I/O Interface, the Console and Booth Termination Panels and other auxiliary devices.

*The Local Synchronous Network (LSN) Com port* - This is the interface for the Interlock and Copy function between CNA-100 systems, Remote Monitors and PC Host.

The front panel is used to setup, program and run the shows. It also displays error and status messages to the user. The front panel incorporates up to nine manual override switches used for emergency manual control. These are rocker type switches and their general functions should be obvious to the operator. All manual controls circumvent the electronic circuitry giving the user the ability to control the major functions in the event of an automation failure. The manual control functions are listed below:

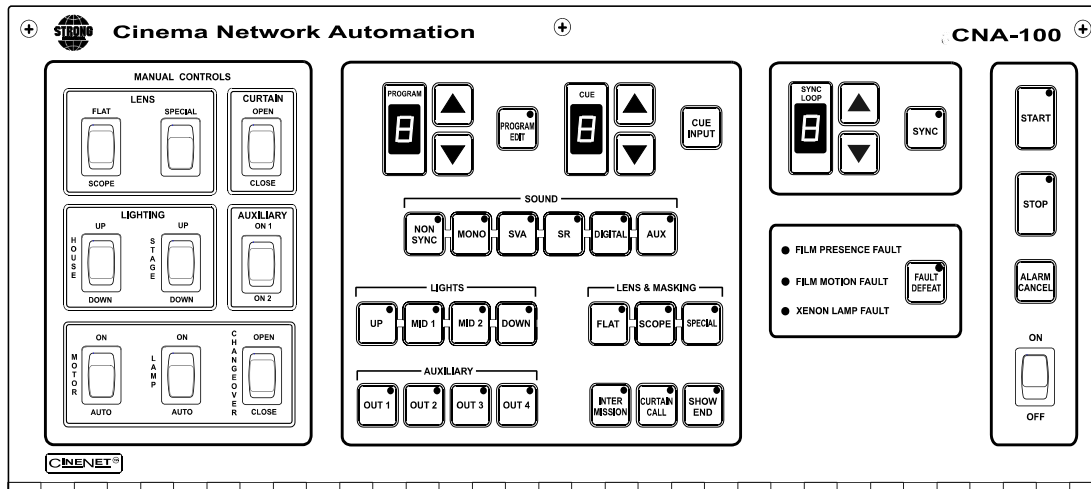

**Figure 1**

1. PROJECTOR - Maintained ON/AUTO
2. LAMP - Maintained
3. CHANGEOVER - Momentary OPEN/CLOSE
4. LENS - Momentary FLAT/SCOPE
5. LENS - Momentary SPECIAL
6. CURTAIN - Momentary OPEN/CLOSE
7. HOUSE LIGHTS - Momentary UP/DOWN
8. STAGE LIGHTS - Momentary UP/DOWN
9. AUXILIARY - Momentary ON1/ON2

### Program Number

Displays the program number to run or edit. Use the up and down cursor keys to select the program number. Up to nine unique programs can be saved.

### Cue Number

Displays the show cue number. During programming use the up and down cursor keys to select the cue number to edit. Up to nine cues can be programmed for a show.

## Programming Keys

These keys are used to program the sound, lens, masking, lights, intermission, curtain call and end of show. LEDs are on each key. The LED is "on" indicating the present state of the output during a show.

### Program Edit Key

This key is used to enter the program edit mode allowing the user to build new or alter existing programs. The LED is on when "program edit" is active. The user may edit any program during a show or between shows.

### Start Key

This key is used to start or restart a show. The LED on the start key will "blink" when the show is *ready to start* or *ready to restart*. The LED is "on" when the show is running, and "off" when the show is stopped.

### Stop Key

This key is used to stop a show. The LED on the stop switch is "on" when a show is stopped, due either to a "local" or "remote" stop input or a fault.

### Sync Key

This key is used to activate the automation for synchronous (interlock) operation. The sync LED will be "on" indicating the automation is in sync mode.

### Sync Loop Number

This displays the Sync Loop number. Use the up and down cursor keys to change the loop number. Up to 9 different loops can be on the sync network. 0 disables the machine from sync operation. The user is prevented from changing the Sync Loop number when sync is enabled with the Sync Key.

### Fault Status LEDs

These LEDs display the status of the fault conditions: *Film Presence*, *Film Motion* and *Xenon Fault*. The LEDs are "off" when there is no fault present. When a fault exists, the LED will "blink" rapidly.

### Power Switch

Supplies power to the automation main controller and termination panels.

### Fault Defeat Key

This key will defeat or bypass the fault inputs (film presence, film motion and xenon lamp). This key is normally used for testing the projection equipment or newly edited programs. It is *not* recommended for normal operation. The LED will "blink" when the Fault Defeat is activated.

## Alarm Cancel Key

This key will cancel the local alarm and all remote alarms. This key is also used to clear any of the latched faults. Pressing the Alarm Cancel key once will cancel the alarm. Pressing the key again will clear the fault condition.

## Cue Input Key

This key provides a manual cue input. This is similar to the cue input from the electronic cue detector or pick off. This key is always active during a show.

## Console Termination Panel

This panel supports the input and output termination interface and provides connections for standard console functions as listed below:

Outputs:

- Projector Motor; On/Off
- Xenon Lamp; On/Off
- Changeover; Open/Close
- Lens Turret; Flat/Scope/Special
- Auxiliary Output; On/Off

Inputs:

- Film Presence
- Film Motion
- Film Tension
- Cue Input
- Xenon Fault

Features:

- High power *dry* relay contact outputs.
- High power override connector for plug-in cable to override switches.
- Projector motor fuse.
- Plug-in I/O CPU Control Board to handle I/O and serial interface.
- Terminal Blocks for connection to the console equipment.

The relays and I/O CPU Control Board get their power from the network cable. The Control Board will plug onto the relay board to provide the I/O and network interface.

## Booth Termination Panel

This panel provides the outputs to control the following functions:

Outputs:

- Top Masking; Flat/Scope/Special
- Side Masking; Flat/Scope/Special
- Curtains; Open/Close
- House Lights; Up, Down, Mid 1, Mid 2
- Stage Lights; Up, Down
- Environment; On/Off
- Slide Projector; On/Off
- Sound Processor; Mono, SVA, SR, Digital 1, Digital 2, Aux 1, Nonsync, Mute, Aux 2, Preamp 1, and Preamp 2.

Inputs:

- Remote Start
- Remote Stop

Features:

- Low power dry relay contact outputs.
- High power dry relay contact outputs for Slide Projector and Environment Control
- A plug-in I/O CPU Control Board to handle I/O and serial interface.
- Override connector for plug-in cable to override switches.
- Override connector for optional override switches.
- Large terminal blocks for user interface.

This Panel (PC board) will connect to the to the Local I/O Network (LIN). The outputs can be configured at the PC Host.

The relays and plug-in I/O CPU Control Board get their power from the LIN cable. This board will generally be mounted in a cabinet on the booth wall, but can also be mounted in the console next to the Console Termination Panel.

## Single Termination Panel

This panel provides the outputs to control the following functions:

Outputs:

- Xenon Lamp; On/ Off
- Projector; On/ Off
- Changeover; Open/ Close
- Slide Projector; On/ Off
- Sound Processor; Mono, SVA, SR, Non-Sync, Digital, Aux, And Mute.
- Lights; House up, House Mid 1, House Mid 2, House Down, Stage Up, Stage Down.

- Curtain; Open/ Close
- Masking; Flat/ Scope/ Special
- Lens; Flat/ Scope/ Special

Inputs:

- Film Motion
- Film Presence
- Film Tension
- Cue
- Xenon Fault

Features:

- Low power dry relay contact outputs.
- High power dry relay contacts for Xenon Lamp, Projector Motor, Changeover Open/ Close, and Slide Projector.
- A plug-in I/O CPU Control Board to handle I/O and serial interface.
- Override connector for plug-in cable to override switches.
- Override connector for optional override switches.
- Large terminal blocks for user interface.

This Panel (PC board) will connect to the to the Local I/O Network (LIN). The outputs can be configured at the PC Host.

The relays and plug-in I/O CPU Control Board get their power from the LIN cable.

## Configuring the System

The LSN can support up to 64 devices (CNA-100/ 150s, CNA-200s, Remote Status Monitors, dimmer control cards, and a Host Computer). **Each device will each require a unique Sync Id number.** Id 0 is reserved for the *Host PC* and Ids 1 through 63 are assigned to eCNA-100s and other devices as necessary. To keep things simple, assign the eCNA-100 Ids starting at 1, corresponding to the house number and working up. The Remote Monitor's Ids, if used, should be assigned to the higher numbers starting at 62 and working down. You may want to keep Id 63 reserved for the portable or *secondary* host.

# eCNA-100 DIP Switch Settings

Current to Version 3.010

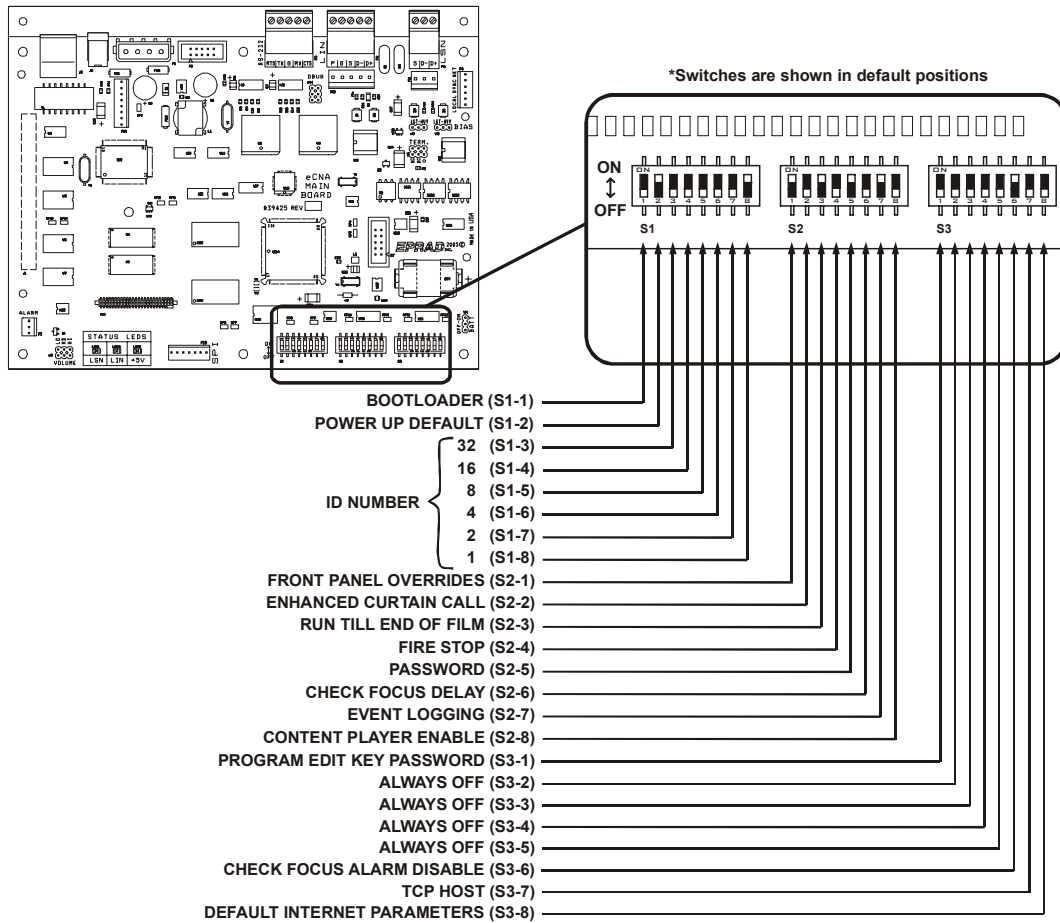

Figure 2

## Switch Definitions

### S1-1 Force Bootloader

- On :Force Bootloader.
- Off :Normal Use. (Factory Default)

### S1-2 Supervisory Defaults

- On :Force “Supervisory Defaults” on power up. Default Supervisory data will be restored on each power up. (Factory Default)
- Off :Will **not** overwrite user-programmed supervisory data on power up. If you change any of the default settings with the Host program this switch must be off or the next time the eCNA-100 is powered up all user settings will be over-written with the defaults.

S1-3 through S1-8 are used to set the ID number. The number is represented as a 6-bit binary number which allows for 64 possible ID numbers (0-63). Do not use 0 (zero) as an ID number. It has been reserved for the PC Gateway Interface. Each bit (switch) has a decimal value. Add up the decimal values to get the ID number. For example, ID number 15 would be 8+4+2+1=15 or a DIP switch setting of 001111. See below.

- S1-3 On :1 Decimal value = 32
- Off :0 Decimal value = 0 (Factory Default)

- S1-4 On :1 Decimal value = 16
- Off :0 Decimal value = 0 (Factory Default)

- S1-5 On :1 Decimal value = 8
- Off :0 Decimal value = 0 (Factory Default)

- S1-6 On :1 Decimal value = 4
- Off :0 Decimal value = 0 (Factory Default)

- S1-7 On :1 Decimal value = 2
- Off :0 Decimal value = 0 (Factory Default)

- S1-8 On :1 Decimal value = 1 (Factory Default)
- Off :0 Decimal value = 0



































































OFF=  ON= 	ID = 16 	ID = 32 	ID = 48 
ID = 1 	ID = 17 	ID = 33 	ID = 49 
ID = 2 	ID = 18 	ID = 34 	ID = 50 
ID = 3 	ID = 19 	ID = 35 	ID = 51 
ID = 4 	ID = 20 	ID = 36 	ID = 52 
ID = 5 	ID = 21 	ID = 37 	ID = 53 
ID = 6 	ID = 22 	ID = 38 	ID = 54 
ID = 7 	ID = 23 	ID = 39 	ID = 55 
ID = 8 	ID = 24 	ID = 40 	ID = 56 
ID = 9 	ID = 25 	ID = 41 	ID = 57 
ID = 10 	ID = 26 	ID = 42 	ID = 58 
ID = 11 	ID = 27 	ID = 43 	ID = 59 
ID = 12 	ID = 28 	ID = 44 	ID = 60 
ID = 13 	ID = 29 	ID = 45 	ID = 61 
ID = 14 	ID = 30 	ID = 46 	ID = 62 
ID = 15 	ID = 31 	ID = 47 	ID = 63 

Figure 3

**S2-1 Front Panel Overrides**

- On :Enable front panel overrides. The Sound, Lights, Lens/Masking and Auxiliary front panel switches will override the outputs without affecting the program. The next instruction will override any manual changes. (Factory Default)
- Off :Disable front panel overrides. The Sound, Lights, Lens/Masking and Auxiliary front panel switches are only used for programming.

**S2-2 Curtain Call**

- On :Enables the Curtain Call function and overrides the original Curtain Call function. Place the Curtain Call cue at a distance before the next cue that is equal to the curtain close time. When the eCNA-100 sees the Curtain Call cue, the curtains begin to close, the changeover closes and sound is muted. At the next cue, the curtains will begin to open. After the CURTAIN CLOSE TIMER counts down to zero, the curtain will be fully open and the changeover will open and the sound is selected.
- Off :Original Curtain Call function. (Factory Default)

**S2-3 Run Til' End of Film**

- On :Enables the “Run til End of Film” function. This overrides the normal 7 second motor off delay. The projector motor will run until the film runs out of the failsafe. (Factory Default)
- Off :Disables the “Run til End of Film” function. The projector motor will shut off after the normal 7 second delay.

**S2-4 Fire Stop**

On :Enables the “Fire Stop” function.

*39331 Booth Termination Board* - Converts the Remote Stop input to a Fire Stop input and the Slide Projector relay (K13) to a Fire Stop output. Fire Stop *acts* like a Remote Stop with the following exceptions:

- Sound is Muted.
- Slide Projector on *39330 Console Termination Board* is turned off *or* held off.
- K13 relay (Slide Projector) on Booth Termination board is turned on.

*39332 Termination Board* - Remote Stop input must be enabled on board. (W1-OPT1 jumper across pins 2 and 3 changes the Film Tension input to a Remote Stop input.) Converts the Remote Stop input to a Fire Stop input. Fire Stop *acts* like a Remote Stop with the following exceptions:

- Sound is Muted.
- Slide Projector is turned off *or* held off.

Off :Disables the “Fire Stop” function. (Factory Default)

**S2-5 Password**

On :Requires use of the password to access many of the functions. (Factory Default)

Off :Disables the password. No password is required to access the functions.  
This switch can be software overridden.

**S2-6 Check Focus Delay**

On :Enables the “Check Focus Delay” function. In Clock Start or Timed Start the alarm will sound prior to the show starting.

Off :Disables the “Check Focus Delay” function. (Factory Default)

The Check Focus feature alerts the operator that the show is about to start. This gives the operator time to make any quick adjustments and to insure the image on the screen is in focus.

**S2-7 Event Logging**

On :Enabled - Events are sent to the Host computer.(Factory Default)

Off :Disabled - Events are not sent to the Host computer.

The eCNA has the ability to send system event logs to a Host P.C. via the LSN connection.

\* See *Host user manual* for more information

**S2-8 Content Player**

- On : Enable  
Off : Disable (Factory Default)

This switch allows the eCNA to interact with a digital content player. Serial commands exchanged between the content player and CNA automation allows the digital projector and film projector to share the screen in a coordinated manner.

*\* See CAI user Guide for further information*

**S3-1 Program Edit Key Password**

- On : Enable (Password required to edit but not to view programs)  
Off : Disable (No password required for program edit) (Factory Default)

“View only” mode indicated by Program Edit LED Flashing

**S3-2 to 3-5 Undefined, Always Off (Factory Default)**

These switches are undefined and should remain in their default “OFF” positions

**S3-6 RCM/RSM-10 “Check Focus Alarm”**

- On : Enable the RSM/RCM-10 Alarm (Factory Default)  
Off : Disable the RSM/RCM-10 Alarm

Enables/ disables alarm on RSM/ RCM 10/ 20. Alarm (when enabled) will sound to warn projectionist to check focus before the start of a show and after check focus delay.

**S3-7 TCP Host**

- On : TCP host routing enabled  
Off : LSN Host routing enabled (Factory Default)

Configures which port the eCNA uses for Host communications. The eCNA can send and receive host information via ethernet or standard LSN depending on this switch’s configuration.

**S3-8 Default internet parameters**

- On : Default parameters used TCP/IP  
Off : User parameters used for TCP/IP (Factory Default)

This switch disables user defined EEPROM parameters and enables default IP of 192.168.0.254 and half duplex communication. This is of obvious value to the technician configuring the eCNA in the field. This selection would allow a unit with unknown IP parameters to be used for troubleshooting or substitution without re-configuring it.

## TCP/ IP (Ethernet) Configuration

The eCNA-100 will need to be configured in order to assist other devices in interfacing with it via ethernet. Configuration is accomplished either with the “Dumb-Terminal” P8, RS-232 port on the eCNA-100's mainboard, or the Ethernet RJ45 connection. The installer will need to configure the IP, Default gateway, and the subnet mask. The eCNA's Hardware or MAC address is also configured during setup. At this time, it is not an option to use the HOST software to configure TCP/IP settings.

### RS-232 Based IP Configuration

The installer can use a windows PC or Laptop running a terminal emulator or any other device with dumb-terminal capabilities and a RS-232 communications port. Settings are as follows: 19,200 Baud, 8 Data bits, No-Parity, 1 stop-bit, and hardware handshaking. With power off, connect the cable from your terminal to P8, upon power up the terminal should come up with the configuration screen shown below, this is the eCNA's Ethernet configuration menu.

Any selections made using this method are stored in the eCNA's non-volatile EEPROM memory and will remain until changed by the user.

*Note: a DIP switch is provided on the mainboard to select a factory default configuration for the ethernet communications port. These settings are as follows:*

IP: 192.168.0.254  
Half Duplex

It should be noted here that the CineNet software can now run on either the LSN as before, or Ethernet with the CineSuite software package.

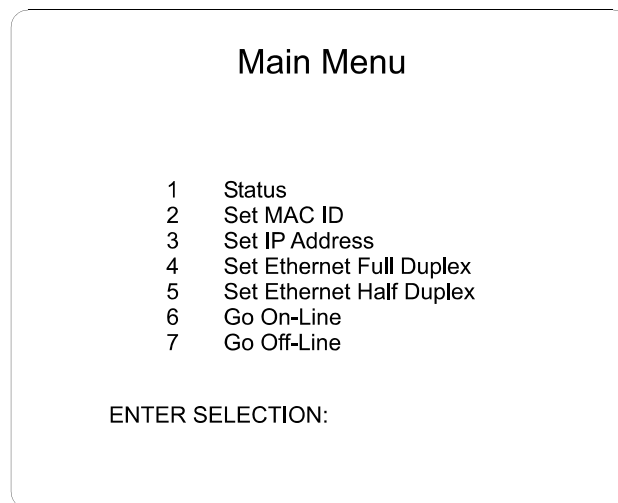

**Figure 4 TCP/IP setup screen (RS-232)**

This is a listing of the menu items encountered while setting up the eCNA's IP address and networking options through the RS-232 interface. Warning: HyperTerminal© will most likely not work when using a PC as a “Dumb Terminal” for altering the eCNA's Ethernet configuration settings. Use Polygon or ProComm Terminal emulator instead

**Main Menu**

- 1 Status
- 2 Set MAC ID
- 3 Set Ethernet Full Duplex
- 4 Set Ethernet Half Duplex
- 5 Set CNA IP Address
- 6 Set Subnet Mask
- 7 Set Gateway IP Address
- 8 Go On-Line
- 9 Go Off-Line

ENTER SELECTION: \_

Selection 1

CNA-100 1.040  
Status:  
MAC ID: dd-dd-dd-dd-dd-dd  
Mode: Full Duplex  
CNA IP Address: 192.168.001.000  
Subnet Mask: 255.255.255.000  
Gateway IP: 000.000.000.000  
CAI: On-Line

Selection 2

MAC ID(dd-dd-dd-dd-dd-dd) :

Selection 3

Setting Full Duplex  
<<<You must cycle power to activate this new parameter.>>>  
Press any key to continue\_

Selection 4

Setting Half Duplex  
<<<You must cycle power to activate this new parameter.>>>  
Press any key to continue\_

Function 5

CNA IP Address(192.168.000.000) :

Function 6

Subnet Mask(255.255.255.000) :

Function 7

Gateway IP(000.000.000.000) :

Function 8

Setting On Line

Function 9

Setting Off Line

## HTML IP Configuration

Ethernet settings can be configured via your web browser when the eCNA is connected to your LAN (Local Area Network). This option provides a means for configuring the IP, Subnet mask, and Gateway IP only at this time. A computer on the ethernet network can access the configuration/status page when the eCNA’s IP address is known and entered in the web browser’s address bar:



Figure 5

Embedded HTML server shown, IP address browser entry directs user to a welcome screen with hyperlink selections. The second illustration is the status page showing various network parameters.

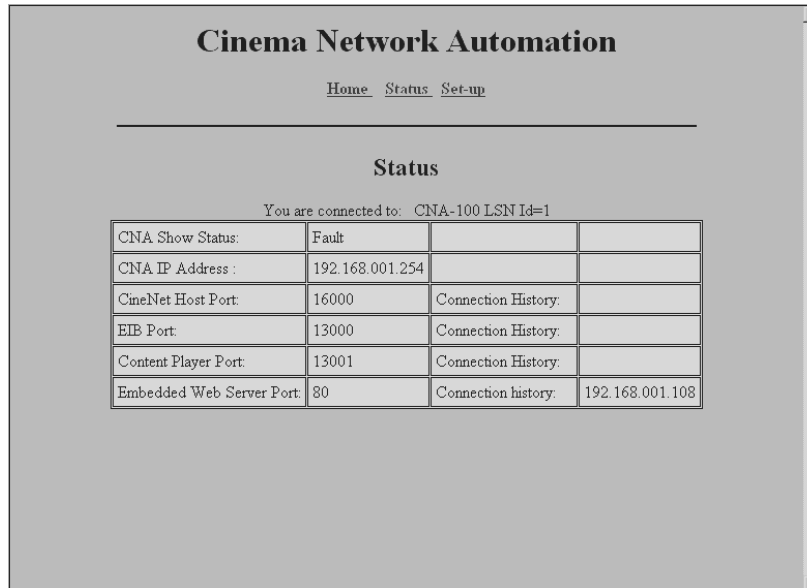

Figure 6

**Cinema Network Automation**

[Home](#) [Status](#) [Set-up](#)

---

**Enter Password To Proceed**

You are connected to: CNA-100 LSN Id=1

Password:

Figure 7

**Cinema Network Automation**

[Home](#) [Status](#) [Set-up](#)

---

**Internet Set-up**

You are connected to: CNA-100 LSN Id=1

CNA's IP Address:	<input type="text" value="192"/>	<input type="text" value="168"/>	<input type="text" value="001"/>	<input type="text" value="254"/>
Subnet Mask:	<input type="text" value="255"/>	<input type="text" value="255"/>	<input type="text" value="255"/>	<input type="text" value="000"/>
Gateway IP Address:	<input type="text" value="000"/>	<input type="text" value="000"/>	<input type="text" value="000"/>	<input type="text" value="000"/>

Warning: This form will change the configuration of the CNA device!

Figure 8

The above windows show the password login screen for the IP configuration page and the configuration page itself. A non-configurable password is used to access the IP settings where changes can be made to the device IP, subnet mask, and gateway IP address. The user is prompted to reboot the eCNA when changes are submitted.

The MAC ID or Hardware address is set by the manufacturer during testing. Inside the front panel on the mainboard there is a label with a serial number and MAC configuration information. Should the installer ever need to change this address it must be done from the (P8) RS-232 port configuration screen, however, this procedure will most likely never be necessary.

## Interface Hardware

The illustration below shows the location of the Ethernet (10Base-T, RJ45) TCP/IP Connector. Also shown is the P8 (RS-232) header used for configuration of the TCP/ IP network settings. In order to use the terminal connection an adapter cable is required to plug into the 10 pin header and interface with a standard PC RS-232 serial port.

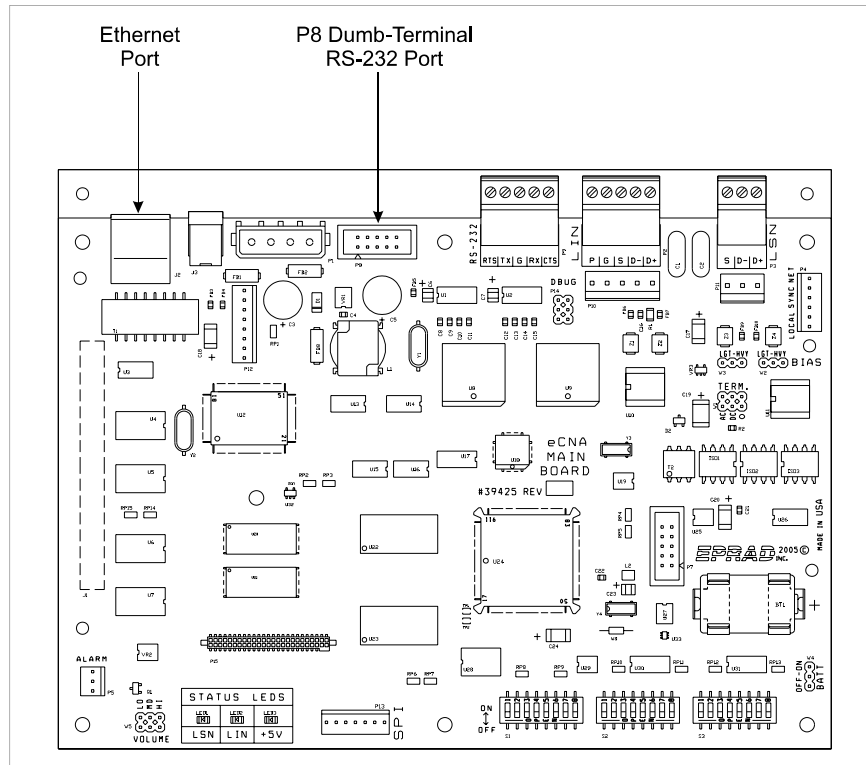

Figure 9

## Ethernet Connection Hardware

The eCNA's ethernet port is of the 10BaseT variety, this means that it communicates at a maximum of 10MB/s. This makes it a natural requirement that the hardware path support this speed. The cable should be of the standard Cat5 type and terminate in RJ45 connections. Twisted pair wiring is used and should follow standard conventions for ethernet hardware. Below is a diagram representing these wiring terminations. The RJ connectors when installed must be of the proper type for the wire used (Stranded or Solid). Sound termination is required for proper reliable performance, as is true for any type of networking connection.

A special tool is used to crimp the RJ45 connector on the wire and practice is usually needed for a reliable termination. Consult your IT staff or a qualified electrician during installation if problems arise.



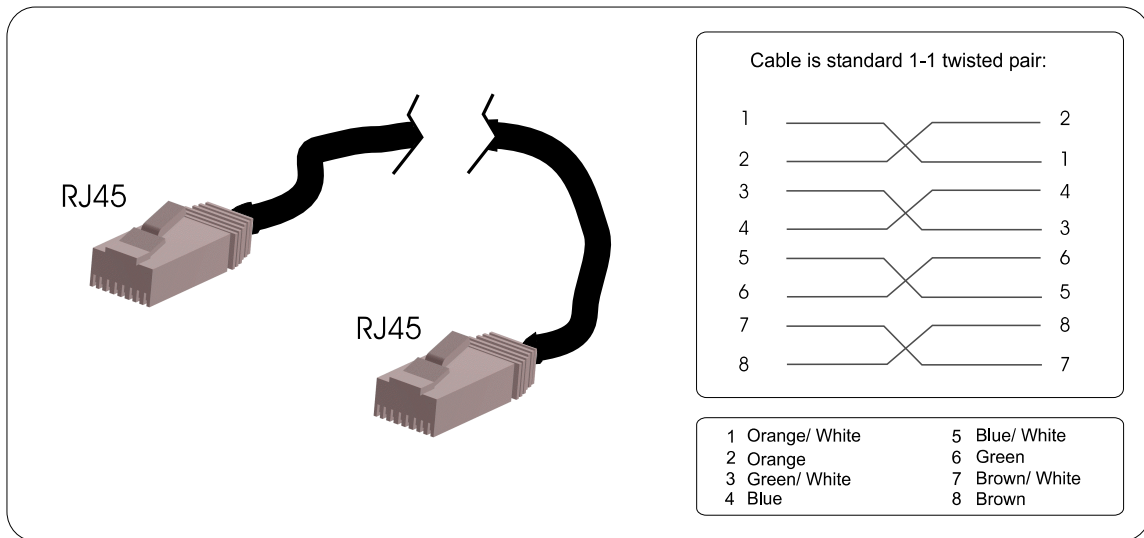

The hub, switch or router used with your network must also be configured to accept 10MB/s network traffic. Most hardware manufactured today accepts, and in many cases automatically configures itself to either 10, 100, or 1000 MB/s. Some older hardware requires a switch to be manually set to the proper network speed.

A simplified wiring connection can also be used, the above cable is a standard store-bought ethernet cable, it may be desirable to wire only the necessary contacts when terminating your own connections. The critical connections are shown in the diagram to the right.

Some users may find it desirable to connect their eCNA directly to their host computer using the ethernet port. In this case a special cable known as a crossover cable must be used. Most hubs and switches have an automatic crossover in them eliminating the need for such a cable, however in the case of a direct eCNA to PC connection the crossover must be hard-wired. The diagram to the right shows the crossover connection.

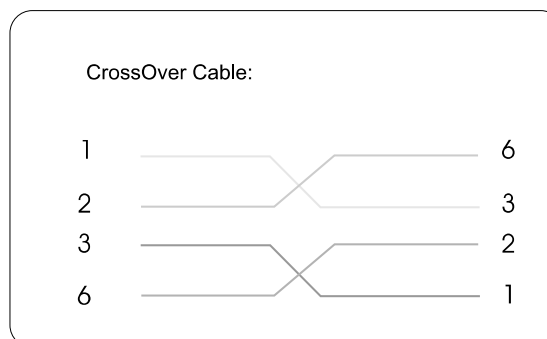
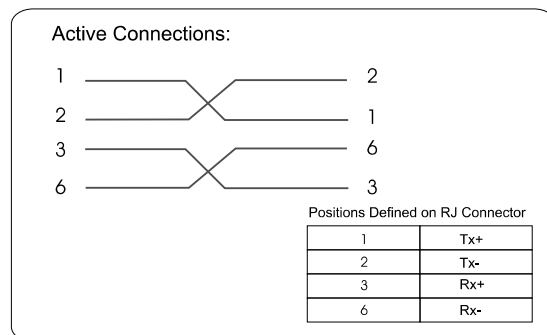

## TCP/ IP Networking Overview

The eCNA should be “behind” your router, plugged into a hub or switch. It is beyond the scope of this manual to describe the intimate details of computer networking. The configuration suggestions given are basic examples designed to illustrate network connection. The internet is a great resource for the novice network user.

The eCNA is not configurable for DHCP (or Dynamic Host Configuration Protocol) addressing as of the writing of this manual, therefore a “Static IP” must be used. The main router with hub or switch connected (or integrated) should be configurable for either DHCP or static IP. Static IP requires that every device, computers, etc... behind the router, be configured for a static IP. This address will not change and every time the Router, computer or eCNA is rebooted, the network’s hardware devices use the same address.

The other option for your router is DHCP with range limiting, or reserved IPs. This will allow any computer or DHCP enabled device plugged into your router (When acting as a DHCP server) to gain an IP address and network access. IF your network is using DHCP and you know the range of IPs used by the DHCP server, the eCNA can be used if the server is configured to accept it outside of that range of numbers. The server must however, never assign the eCNA’s address to any other device. This situation would cause a duplicate IP conflict and require intervention. Some DHCP software allows IP range limiting and most allow static addressing.

Below are two very basic examples of possible network designs. The first shows eCNAs connected behind a router/ switch/ hardware firewall. The host PC can be configured to utilize the internet via the router’s uplink, the decision to do so is up to the administrator and recommended only if remote functions are actually necessary. The Host PC can be used for everyday tasks like email and web-browsing.

The second illustration shows an isolated intranet where there is no outside access, all of the network components and hardware are dedicated to the eCNA/ theatre automation network. This of course will make advanced remote tasks through the CineSuite software package unavailable unless you are directly connected to your local network. The administrator must weigh their options and decide which CineSuite features are likely to be used, and which network configuration will provide proper support for other ethernet-based equipment that may be present. Although not a major threat in most cases, the hazards of computer email viruses, Trojan horses and worms could affect the operation of all devices over ethernet. Proper care must be taken to limit exposure on any computers connected. The eCNA is not susceptible to virus infection, but the increased network activity of an infected PC would most likely slow your network to a crawl.

It is important that the SW3-7 and 3-8 DIP switches are placed in their proper positions during ethernet set up 3-7 sets the default parameters. Knowing the eCNA’s IP address and using the “Ping” command from a PC can let you quickly determine the status of your network’s hardware. Switch 3-8 configures the mainboard for either ethernet or LSN networking. If this switch is not in the proper location, ethernet functionality will be limited.

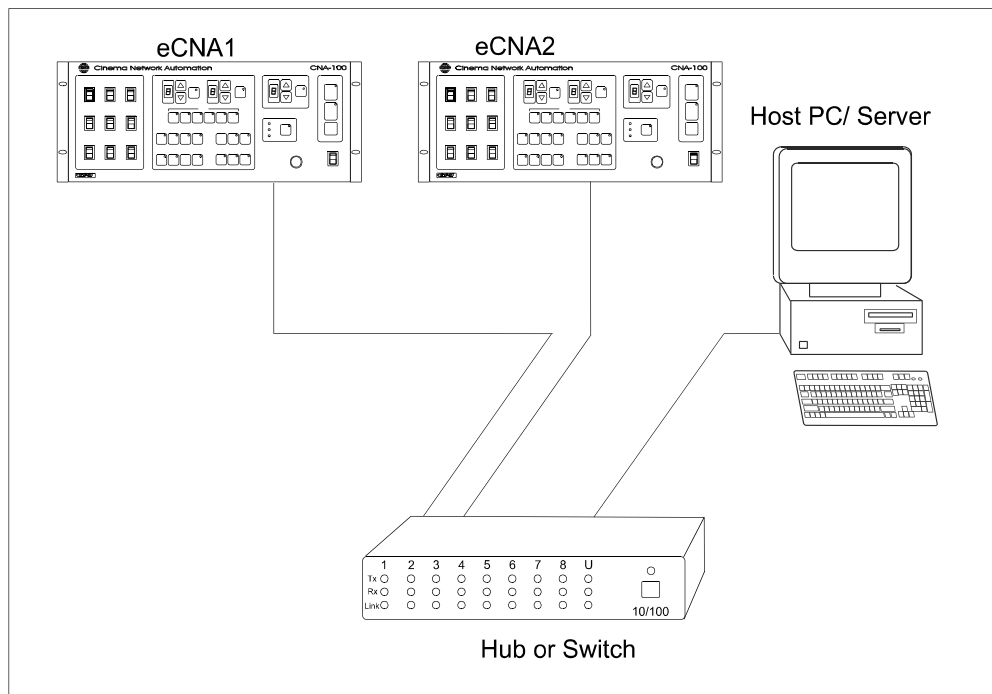
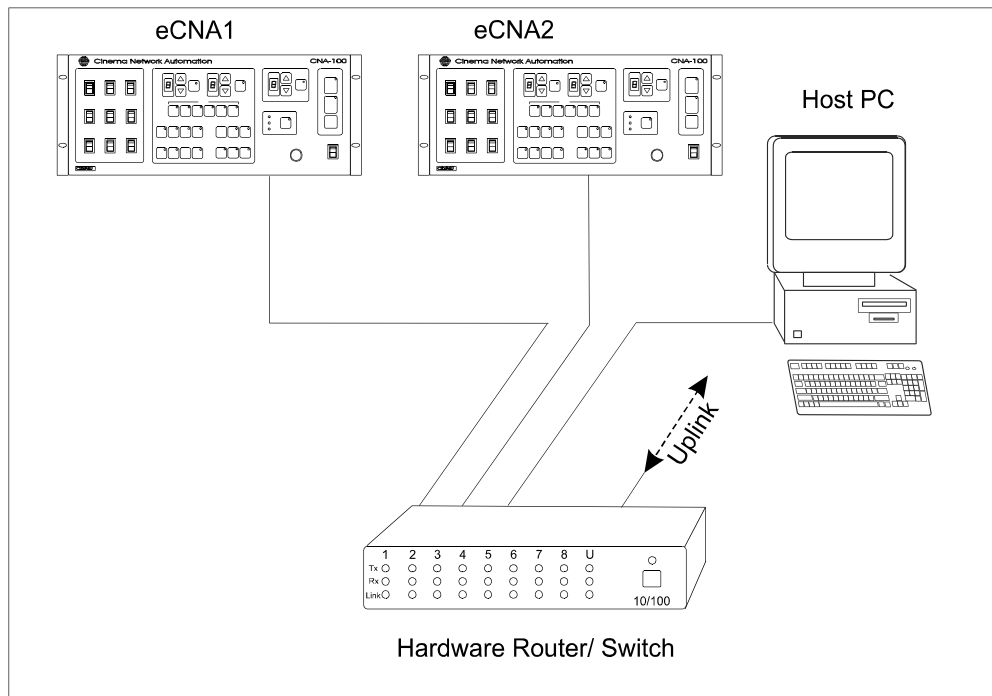

Figure 10

## Alarm Loudness setting

The alarm loudness can be set for one of three intensities; LOW (87 dBA), MEDIUM (94 dBA), HIGH (98 dBA). See below.

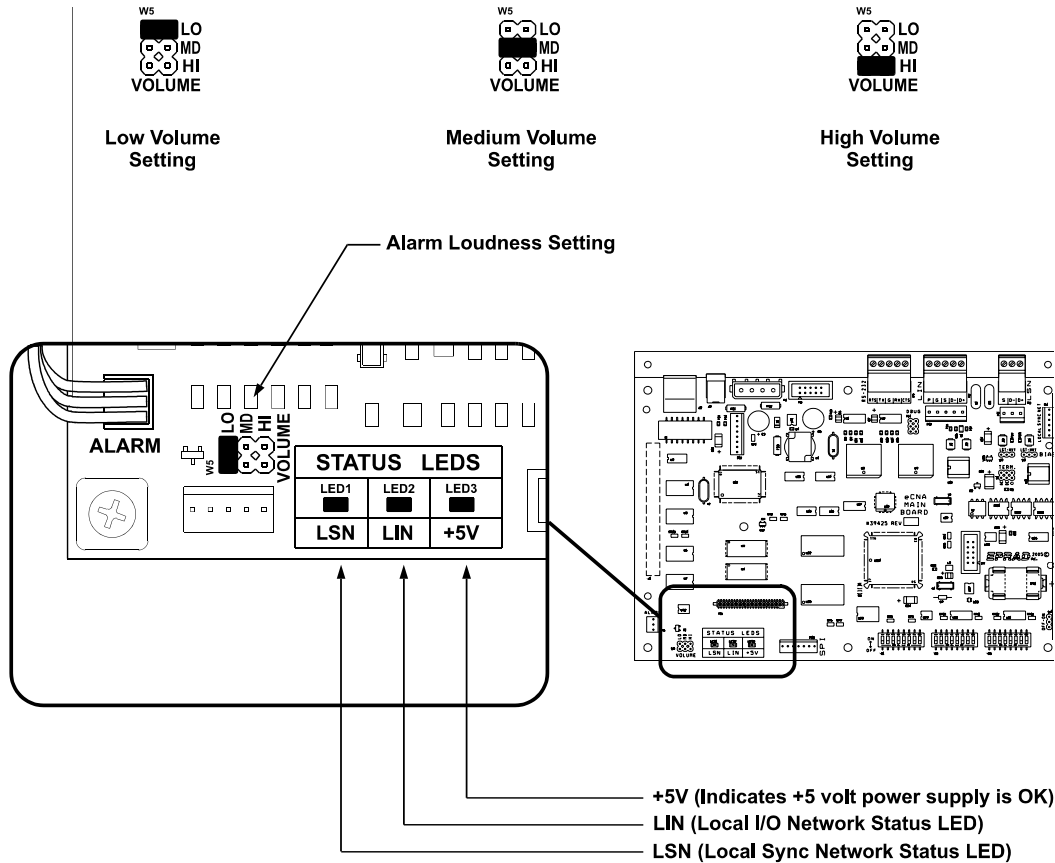

Figure 11

## Status LEDs

There are three status LEDs on the 39425 Main CPU Board. These indicate the status of the +5 volt power supply, the LSN and the LIN. Following are the three conditions for the LIN and LSN LEDs:

*Fast Blinking Rate:* The eCNA-100 computer is working and is communicating properly.

*Slow Blinking Rate:* The eCNA-100 computer is working, but is *not* communicating.

*Off:* The eCNA-100 computer has a problem.

## Section 2

### SETUP

STOP - Please note at this point you should have completed the entire installation of the automation system. If you have not, go to the *Installation* manual and complete it before proceeding.

### Programming the eCNA-100

Programming is accomplished with the *Programming* keys and the *Program* and *Cue* numbers. The eCNA-100 gives the user the ability to build and store up to 9 different programs. Each Program can use up to nine cues.

The following steps describe how to edit a program:

1. Press the PROGRAM EDIT key to activate the *edit mode*. The PROGRAM EDIT LED will toggle "on". The CUE up and down arrow keys are enabled and the PROGRAM and CUE displays will stop blinking *if* show is in progress.
2. Select the program to edit with the PROGRAM up or down arrow keys.
3. Program the Sound, Lens and Lights for each cue using the programming keys. Program the Auxiliary outputs (OUT 1 through OUT 4) if an 'Aux Board' is connected to the system. One or more of these outputs can be on at a time.
4. Use the SHOW END key to indicate the end of the program.
5. Select a different program to edit or press the PROGRAM EDIT key to de-activate *edit mode*. The PROGRAM EDIT LED will toggle "off". The PROGRAM number and CUE number *up* and *down* arrow keys will be disabled and the displays will slowly blink if the show is in progress.

Following are some simple rules to remember when programming:

Programming a SHOW END cue locks out subsequent cue numbers, keeping you from scrolling to a larger cue number.

You may edit any program while a show is in progress (including the program that is running).

When a show is in progress and you are *not* in the PROGRAM EDIT mode the PROGRAM and CUE number *up* and *down* arrow keys are disabled.

## The INTERMISSION and CURTAIN CALL Keys

These are two special programming keys that allow the user to easily program a Show Intermission and a Curtain Call. The INTERMISSION KEY is used to program a show intermission at the selected cue. The cue then initiates the intermission sequence as follows:

Changeover Close
Lights
Sound
Curtain Close
7 second delay
Xenon Lamp Off
Projector Motor Off
Slide Projector On

The Intermission is terminated and the show is re-started either by a START input (remote or local) or a CUE input (remote or local). If the show is re-started by a START input, only the projector motor and lamp are turned on. The next film cue will initiate the show start sequence. The show start sequence is as follows:

Start
Xenon Lamp On Projector Motor On
Cue <i>n</i>
Lens/Masking Lights Curtain Open
7 second delay
Slide Projector Off
1 second delay
Changeover Open Sound

If the show is re-started with a CUE input, there is *no* need for a show start cue.

The show start sequence is as follows:

CUE
Xenon Lamp On Projector Motor On Lens/Masking Lights Curtain Open
7 second delay
Slide Projector Off
1 second delay
Changeover Open Sound

The "Curtain Call" function will issue a curtain *close* at a selected cue. For example, suppose you wanted your curtains to close and the end of your trailers and open back up at the start of your feature presentation. You would place a cue at a distance before the end of the trailer that is equal to the curtain close time and another cue at the beginning of the feature. The sequence of events are as follows:

Cue <i>n</i> (with Curtain Call)
Curtain Close Sound (if programmed) Lights (if programmed)
Cue <i>n+1</i>
Lens/Masking Changeover Close Lights Curtain Open
7 second delay
Changeover Open Sound

## Operating the eCNA-100

In the "Ready to Run" state, the FILM PRESENCE LED will be "off", and the START LED will be blinking. Select the program 1 through 9, that you want to run with the up/down arrow keys. Press the START switch to start the show. The START LED will toggle "on".

When a show is running, the current states of the Sound, Lens, Lights and Auxiliary will be shown with the LEDs "on". The cue number displayed is the next cue the eCNA-100 is waiting to see.

When troubleshooting a program or system the operator can press both the START and STOP keys simultaneously to force a show to quit.

## Soft Manual Overrides

During run mode, pressing any of the Sound, Lens, Lights or Auxiliary keys will drive the output to that state. Note: This will not alter the saved program. At the next cue the program will override any manual changes.

## Synchronous Operation

The eCNA-100 systems are capable of running film synchronously in a multi-projector booth. The eCNA-100 can be programmed for any one of nine sync loops and allows nine different sync loops on the network at one time. Pressing the SYNC key will activate the sync operation and disable the up/down arrow keys. (This prevents the machine from joining another sync loop that may be running and causing a fault on those machines when it drops off the loop.) To change the SYNC LOOP number, press the SYNC switch to deactivate. Set the loop number with the up and down arrow keys and press the SYNC switch again to activate. The LED on the SYNC switch indicates whether sync mode is active.

To run in sync the following conditions must be true:

1. A *sync cue* must be added to the beginning of the film. This is the first cue that is seen by the automation. It acts to initiate the start up sequence for each machine.
2. Sync Mode on each automation in the loop must be enabled.
3. The sync loop number on each automation in the loop must be the same.

To begin a movie, insure that the sync cue is positioned before the cue detector on the first machine. Press the START switch on any machine in the loop. All projectors will start simultaneously. As the sync cue passes through each projector, the show start sequence will initiate.

At the end of the show each machine will shut down independently as the tail of the film runs out of the projector. On endless loop systems all projectors will continue to run until the last machine sees the end cue. At that time all projectors will shut down simultaneously.

## System Status Messages

The eCNA-100 contains a list of status messages that can be displayed due to various internal or external conditions. Most of these messages given indicate system faults. There are also some internal power up and reset diagnostic messages, most of which will not and should not be displayed under normal operating conditions.

## Fault Condition Messages

The Fault Condition messages can be divided into three categories: Internal *memory* faults, *run-time* faults and *failsafe* faults.



## Memory Faults

The internal memory faults are generated when there is a "checksum" error. Briefly, a checksum is an arithmetic sum of the contents of memory that is stored in the memory itself and is re-computed and checked each time the eCNA-100 is powered up. Each of the Programs (1 through 9) and the System Parameters have a checksum. The fault messages are displayed and "blinked" rapidly on the three digital displays.

<u>Message</u>	<u>Description</u>
P 0 1	Program 1 Checksum Fault
P 0 2	Program 2 Checksum Fault
P 0 3	Program 3 Checksum Fault
P 0 4	Program 4 Checksum Fault
P 0 5	Program 5 Checksum Fault
P 0 6	Program 6 Checksum Fault
P 0 7	Program 7 Checksum Fault
P 0 8	Program 8 Checksum Fault
P 0 9	Program 9 Checksum Fault
P A r	System Parameters Checksum Fault

If any of the *Program* memory faults are displayed on power up, *clear* the fault by pressing the ALARM CANCEL key. Press the PROGRAM EDIT key to enter the edit mode. Cursor to the program that has the checksum error. Scroll through the program to verify it. If all the steps look okay, press any key to re-calculate the checksum. Press the PROGRAM EDIT key again and cycle power to verify that there are no other checksum errors.

A *System Parameters* memory fault will be displayed if there is a checksum error. This error must be cleared from the *Host PC*, by copying the system parameters from the Host Program to the eCNA-100. If you are not using a Host PC, the system will be using the *default* parameters and can not issue a System Parameters Checksum Fault.

## Run-Time Faults

These three messages will be displayed if there are the following communications faults.

<u>Message</u>	<u>Description</u>
L I n	Local I/O Network Fault
L S I	Local Sync Interlock Fault
L S C	Local Sync Communications Timeout Fault

The Local I/O Network Fault is caused due to a loss in communications with a Local I/O Network device or another network problem. This could be the Booth Termination Panel, Console Termination Panel or other I/O Network device or a wiring problem.

A Local I/O Network fault will cause the eCNA-100 to display "L I n". This fault will cause a shutdown during a show or prevent a show start between shows. This fault is latched and you are required to press the ALARM CANCEL key to clear the fault. Although this will cancel the fault and allow a show to start, there is a problem with the Local I/O Network or one of the devices and it must be repaired.

A Local Sync Interlock Fault is caused when either a master or one of the slaves in the sync loop has lost its sync input (sync switch). All eCNA-100s on the sync loop will display "L S I" and sound their alarms. This message will also be displayed if one of the units on the loop had a "watchdog reset". If this was the case, all units will display this message except for the one that had the watchdog reset.

A Local Sync Communications Fault is caused when there is a loss of communications with a unit on the sync loop. This could be due to a loss of power of the master or one of the slaves on the loop. In this case all units on the sync loop would display "L S C" except for the one that lost its power. This fault can also be caused by defective wiring, such as an open or short on the LSN communications link.

## Sync Interlock Failsafe Fault

This fault indicates the master or one of the slave eCNA-100s has a failsafe fault that is preventing the interlock loop from *resuming* a show. The following message is displayed to indicate this fault.

<u>Message</u>	<u>Description</u>
L S r	Not Ready To Resume Fault
L S r	Need Master To Resume Fault
L S r	Not Ready To Run

The "Not Ready To Resume" Fault indicates that the automation cannot start a show because a least one of the eCNA-100 remotes are not in the "Ready to Resume" condition.

The Need Master To Resume Fault indicates that there is no master. The master may be lost if the communication wires are disconnected, power is lost or the sync input (sync switch) is not enabled at the master.

The Not Ready To Run Fault indicates that the automation cannot start a show because a least one of the eCNA-100 remotes are not in the "Ready to Run" condition

## Event and Show Logs

When running Host software the eCNA-100 is capable of sending data over the LSN to a Host PC. This is a historical record of automation activity including faults, starts, stops, cues and other occurrences. Show logs contain data specifically about a particular show, this data can include show numbers, events and times that the events occurred, total down time, and many other important parameters. See the Host manual for more information on event and show logs.

## Program and Configuration Copy Functions

The Host software package allows the user to copy individual programs and configuration details from and to your eCNA-100. Due to limitations set by the front panel's attributes, the Host package must be used to access these functions.

## Supervisory

Supervisory configuration is only accessible via the Host program, system variables such as lighting levels for the QDC-400 and sound configuration on the RVC-5, as well as system settings including Delays, password, and output configurations can all be set up here. See the Host user guide for further information on these functions.

## Power Up Messages

Upon power up, the eCNA-100 will display a series of messages. The following messages should be displayed at power up:

Message	<u>Description</u>
4 0 3	Version Number (2 seconds)
2 3 7	Checksum Number (2 seconds)
P U P	Power Up Reset (2 seconds)

These messages will be displayed in this order each time the eCNA-100 is powered up. Each message is displayed for about 2 seconds. The first message is the software version number (version 4.03). The second is the software checksum number, and the last message indicates to the user that it is a power up condition.

## Additional Software

### CineNet Host Software Package

The eCNA-100 automation is optimally configured and used with the CineNet HOST software package. The Host program allows setup, data transfer and programming in a user-friendly format. Additional hardware and software are required. First there must be a Host Computer, this can be any DOS-based PC with either 1 free ISA slot or an RS-232 Serial port that is not in use, installed on that PC there must be CineNet Host networking software. This software allows the PC to interface with the CNA. The only additional piece of hardware required is a proprietary network controller. This can be in the form of an ISA card installed in the PC, or a convenient external package such as the VNC or PCI-64 network interface.

See the CineNet HOST user manual for further details on installation.

Host software provides Event logging, both LIN and LSN Network status, configuration, and programming/ copy functions.

## CineSuite Software Package

The CineSuite software package is a more advanced version of HOST software including two software applications:

*CineSuite Manager:* This is the main user interface. When creating CNA programs, settings CNA supervisory functions or monitoring CNA operations, this is the application that will be used.

*CineNet Driver:* This is the software application that connects the CNA Gateway and automations to the computer. It must be running in the background when using the CineSuite Manager.

The CineSuite software operates over TCP/IP communications protocol meaning that it can be used in conjunction with the internet via a modem or any ethernet connection. It allows remote access to the automation network and provides a means of remotely monitoring devices on the CNA network. CineSuite Reporter software has a full color interface for quick identification of remote problems. Reporter can also email status reports to managerial personnel and generate reports over long periods of time in order to gather important performance data.

CineSuite similarly requires a Host PC and a hardware interface device. The Host PC must be at least a 486/66Mhz running Windows 95 or above. The CineSuite package is constantly under development with new features being added regularly. See the CineSuite Guide for additional information regarding the installation, configuration, and implementation of this software

## Timing Diagrams for the eCNA-100

The following Timing Diagrams show timer values, output configurations and cue events for all the outputs. **Timers and output configurations such as pulsed/maintained, power up and fault conditions are defaulted on the eCNA-100, and can only be changed with the Host Program.** These timing diagrams can be extremely useful to help understand the operation and capabilities of the eCNA-100. The first timing diagram shows the “Standard Operation” from power up to show end. Standard Operation implies a running a program with no interruptions (stop or faults) or special effects (curtain call or intermission). The defaults for each outputs are indicated in the last column of the timing diagram. Default timer values and pulse durations are indicated in the bottom margin of the timing diagram. The diagram indicates automatic and programmed outputs.

The second timing diagram shows the Fault/Stop Shutdown and Restart Sequence. The area of interest is the shaded portion of the diagram. This shows the default ‘Fault-to’ conditions:

Projector Motor and Lamp = OFF	Sound = NON-SYNC
Slide Projector = ON	House Lights = UP
Changeover = CLOSE	Stage Lights = UP

These default conditions can be configured in the eCNA-100 Set-up Supervisory section of the Host PC Program.

The third timing diagram shows the Intermission Stop Sequence. The area of interest is the shaded portion of the diagram. At the Intermission cue the Changeover and Curtain will close. Seven seconds later the Projector Motor will shut off and the Slide Projector will turn on. Sound, Lights and Out 1, 2, 3, and 4 can be programmed for any state during the intermission. A Restart will start the Projector Motor and a film cue will initiate the show start sequence.

The last timing diagram shows the Curtain Call Sequence. The area of interest is the shaded portion of the diagram. At the Curtain Call cue, the curtain begins to close. The ‘next’ cue will begin to open the curtain. The ‘curtain close time’ is determined by the distance between the curtain call cue and the next film cue. Sound, Lights and Out 1, 2, 3, and 4 can be programmed for any state during the Curtain Call.

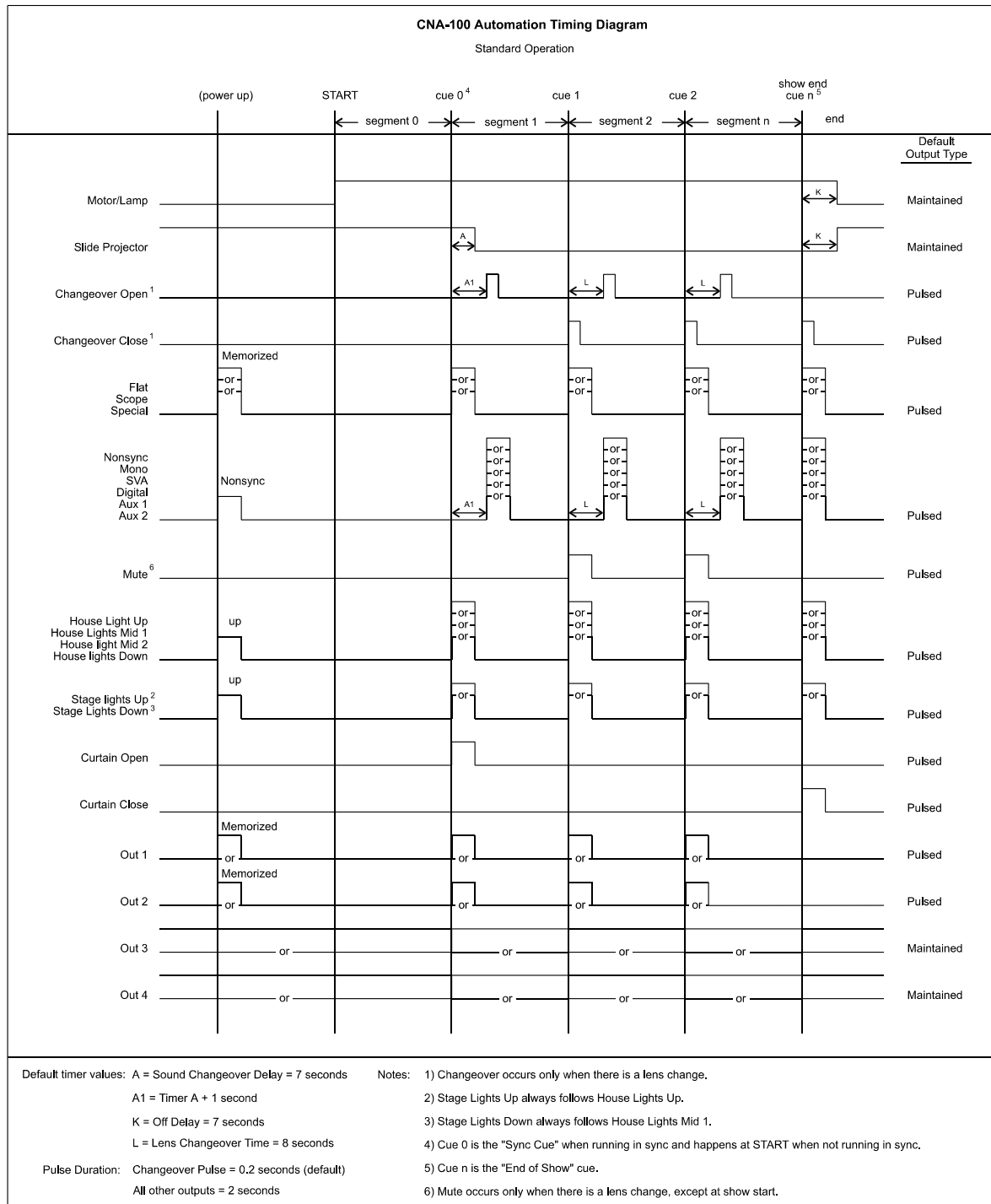

Timing Diagram 1

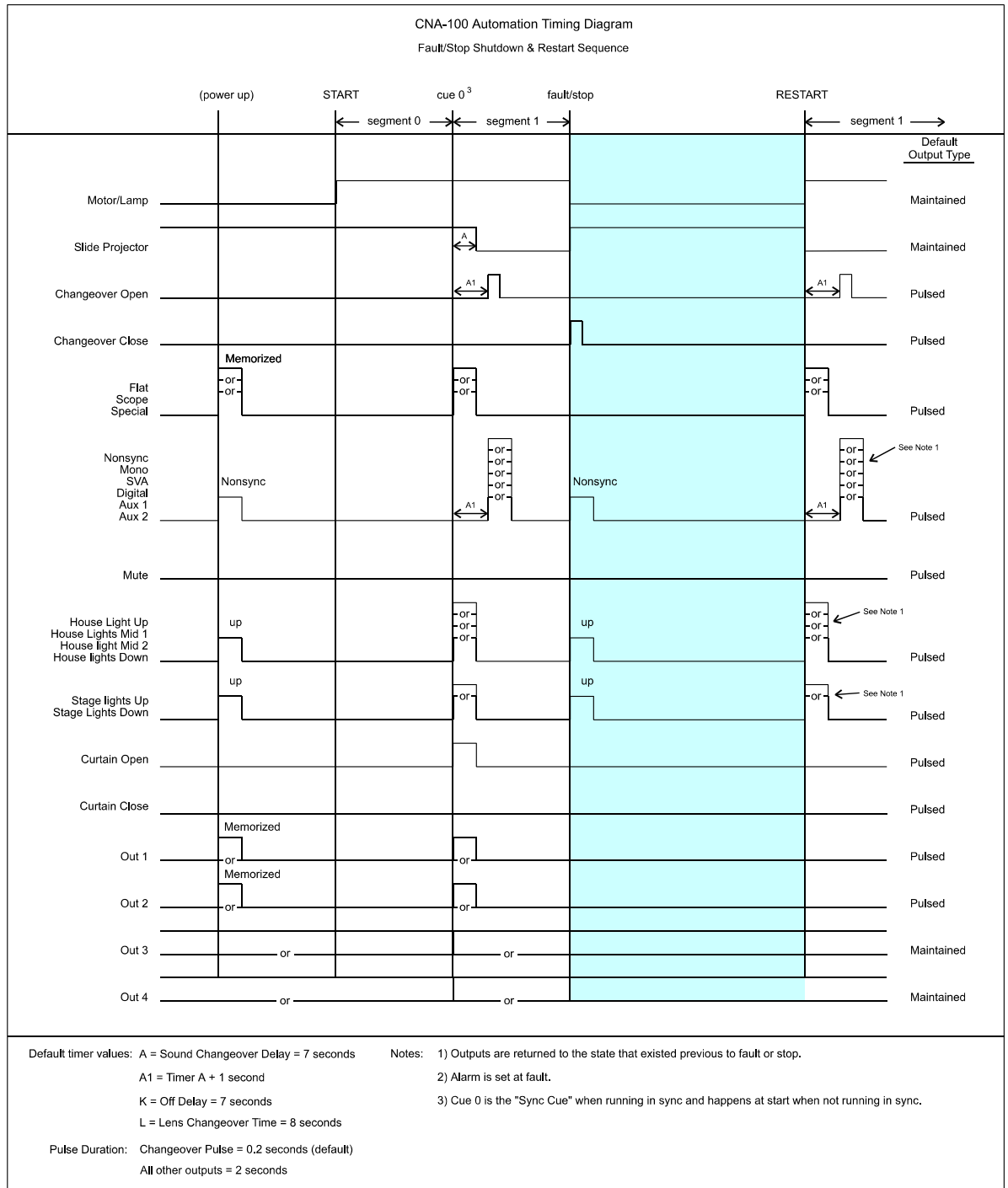

Timing Diagram 2

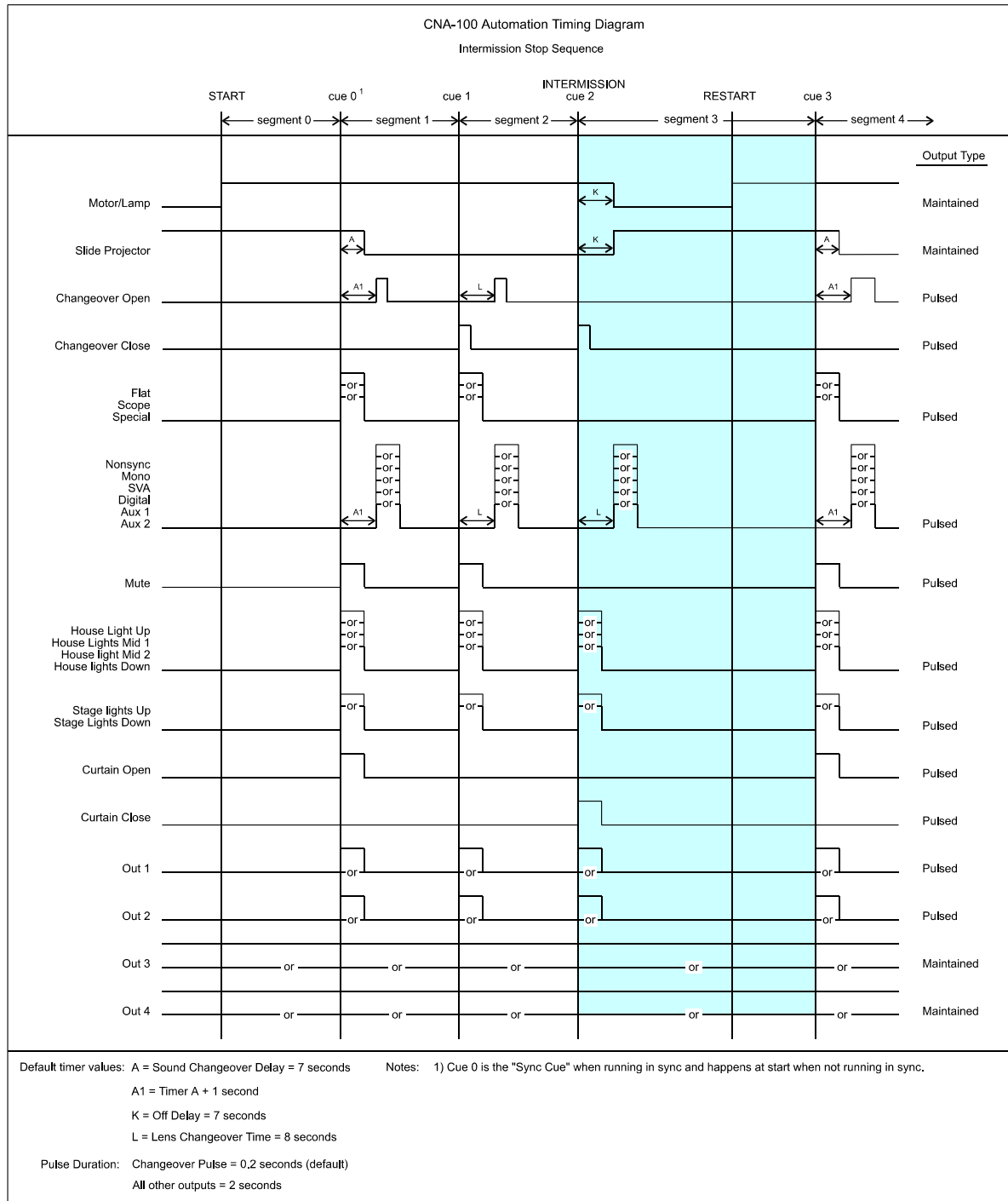

Timing Diagram 3



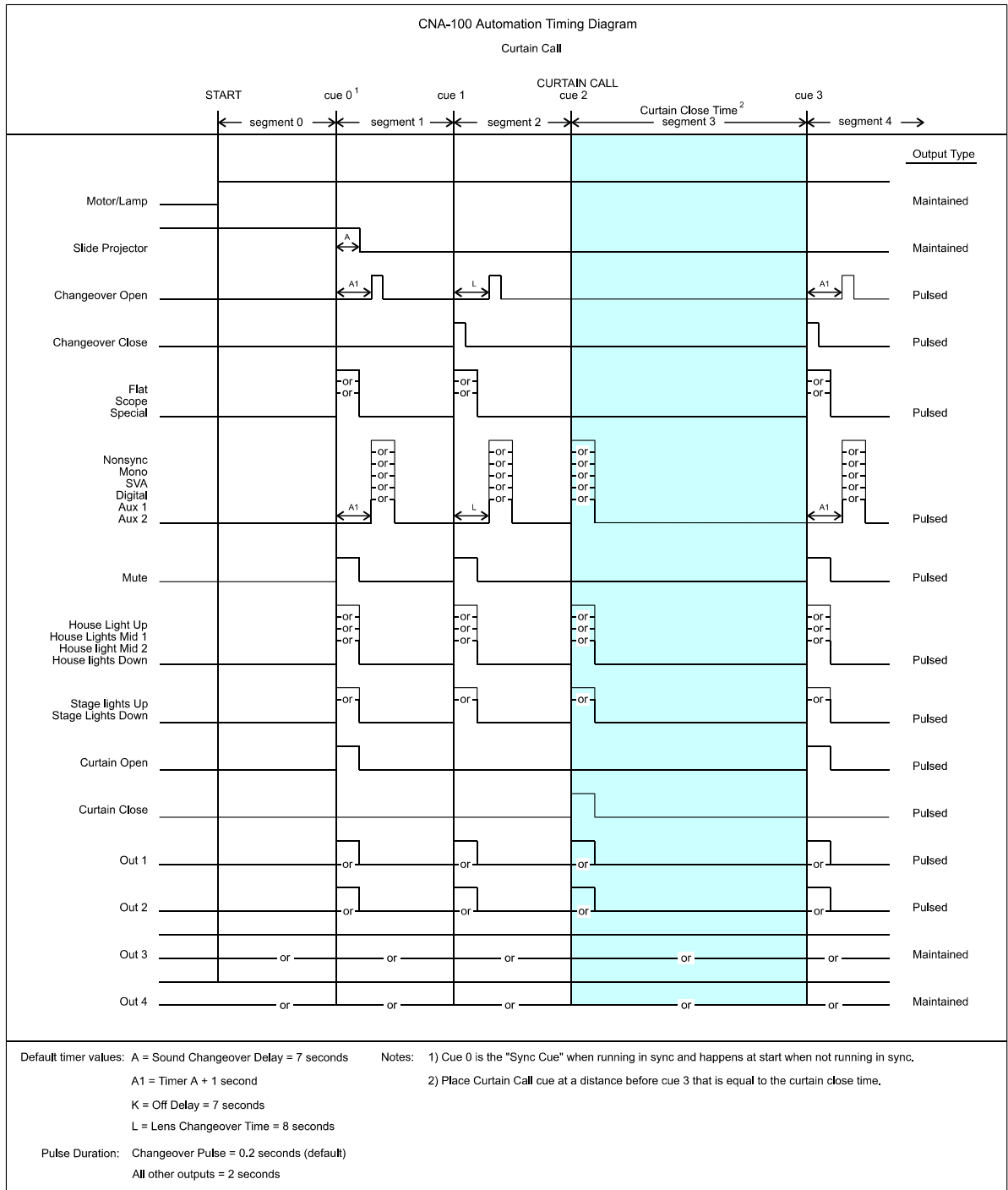

Timing Diagram 4

# ADDENDUM

## Software Changes

This section details the eCNA-100 software changes.

**Version: 4.010**  
**Checksum:103**  
**Date:1/21/05**

Added new System Parameters flag to allow better control of the Password. This new flag now “overrides” the existing DIP Switch control as follows:

<u>Flag</u>	<u>Description</u>
Default	Use the existing S2-3 logic (On=password, Off=no password).
Off	No password required (regardless of S2-3 setting).
On	Password required (regardless of S2-3 setting).

If you are using a Host program with the Network, setting this flag to other than the “Default” state requires a new version of the Host Program or you may lose this setting at the CNA.

Added Edit field to Setup CNA System screen 140 to allow changing this flag locally:

```
[Password Control]
[      Default]
```

S3-6 inhibits the serial output flag that causes the RCM-10/RSM-10 Remote Station to sound the alarm for the “Check Focus Delay” when the CNA starts a show. The Switch settings are as follows:

<u>S3-6</u>	<u>Description</u>
Off	Enable the RCM-10/RSM-10 “Check Focus Alarm”.
On	Disable the RCM-10/RSM-10 “Check Focus Alarm”

Added logic to Screen 111 Setup CNA System to edit the password.

```
[Password      ]
[      1234]
```

This new parameter replaces “spare” bytes that should be zero, which will cause the password to be defaulted the first time this version is run. (This results in a “MEM FLT:SET-UP” the first time (only))

Added programmable “power-up” states for:

Masking (Flat, Scope, Special, None, No-op)  
 Sound (Non-Syn, Mono, SVA, SR, Dig 1, Aux 1, Dig 2, Aux 2, Mute Off, Mute On, No-op)

At this time these states can only be defined at the Host.

Added programmable “fault-to” states for:

Lens	(Flat, Scope, Special, None, No-op)
Masking	(Flat, Scope, Special, None, No-op)
sound	(Non-Syn, Mono, SVA, SR, Dig 1, Aux 1, Dig 2, Aux 2, Mute Off, Mute On, No-op)
House Lights	(Up, Down, Mid 1, Mid 2, No-op)
Stage Lights	(Up, Down, No-op)

At this time these states can only be defined at the Host.

Fixed 2 places that were implemented differently than the CNA-200:

- a. Reworked Feature Start Time Routine (FNFST) to return the same parameters as the version in CNA-200. This (clock start) feature is not enabled but the Content Player Logic for status calls this routine.
- b. Also fixed call to Log “Automatic Cue 0 Event” to set the \$20 bit in CUEFLG prior - previous version might not have logged this event.

Corrected Flash Status Subroutine (FST) to correct possible Watchdog trip when the Host accesses the Flash Status information.

**Version: 4.020**

**Checksum: 179**

**Date: 4/18/05**

Now correctly displays the eCNA-100 Version Number on power up.

The previous version displayed only the low byte of the two-byte version number. (The number 401 (\$0191) was incorrectly displayed as 145.)

**Version: 4.030**

**Checksum: 237**

**Date: 4/28/05**

Fixed debug screen version number format, changed P8 edit logic operation to allow proper configuration of MAC address: xx-xx-xx-xx-Dx-xx (Previous version would not allow re-configuration of a MAC address with a “D” in the shown location).

## Bootloader Changes:

This section documents changes in the eCNA's bootloader program structure:

### **eCNABOOT v2.000**

**Checksum: 57159**

**Date: 4/20/04**

This version requires eCNA mainboard 39425

Modified chip select and H16 initialization to run in the new eCNA mainboard.

Note: source was not ported to Metrowerks for this

### **eCNABOOT v2.00a**

**Checksum: 55153**

**Date: 8/10/04**

Ported over to metrowerks. Modified chip select and H16 initialization to run in the new eCNA mainboard with 29f040 flash. Added tcp/ip stack and dumb term task to support ethernet config on P8. Added basic HTTP web configuration support. Added LSN packet routing support for new TCP host. The CNA listens on port 16000.

Added S3-1 default internet parameters function, S3-2 TCP host routing enable, Default MAC ID is automatically defaulted to 00-d0-ad-ff-00-01 if found invalid. increased shut-down delay for go to app and go to bootloader from 5-7 seconds.

### **eCNABOOT v2.010**

**Checksum: 4126**

**Date: 1/21/05**

Updated TCP/IP stack to v1.1.0

PGPO is now initialized low for compatibility with the next rev of hardware.

### **eCNABOOT: v2.020**

**Checksum: 1293**

**Date: 4/28/05**

Fixed edit logic for MAC ID on dumb-term (P8 Port). Previously could not re-edit ID# if it had a "D" in location: xx-xx-xx-xx-Dx-xx

## Supervisory Defaults Explained:

### eCNA-100 Supervisory

The mainboard Dip Switch #1 position #2 is used to restore factory defaults to your CNA's supervisory settings. This configuration is a default set of parameters that your eCNA had when it left the factory.

When this switch is OFF, any custom supervisory settings are saved and restored upon power-up. These are the parameters that the user defines in the process of configuring an automation for a particular installation.

When this switch is in the ON position, factory defaults are restored each time power is cycled. All user defined supervisory parameters are cleared and the original factory defaults are loaded.

Below is a listing of Supervisory default parameters accessible from the eCNA Host Supervisory menu:

1-System Parameter:	Value:
Sound Changeover Delay (Sec)	7
Lens Changeover Delay (Sec)	8
Lens Changeover Pulse (Sec)	.2
Failsafe Delay (Sec)	1
Cue Factor Default	.001
Password Control	Default
Password	xxxx
Cue Learn Mode	Manual
Timed Start	Disabled
Check Cue Fault	Disabled
Missed Cue Fault	Disabled
Time Format	12Hr
Remote Stop Alarm Time (Sec)	30
Out 1 Controls	None
Out 2 Controls	None
Out 3 Controls	None
Out 4 Controls	None

Output:	Contacts:	Power-up:	Fault-To:
Lens	Pulsed	No-Op	No-Op
Masking	Pulsed	No-Op	No-Op
Sound	Pulsed	Non-Sync	Non-Sync
H. Lights	Pulsed	Up	Up
S. Lights	Pulsed	Up	Up
Curtain	Pulsed	None	No-Op
Slide Proj	Maintained	On	On
Out 1	Pulsed	No-Op	No-Op
Out 2	Pulsed	No-Op	No-Op
Out 3	Maintained	No-Op	No-Op
Out 4	Maintained	No-Op	No-Op

**2-Dimmer**

	Variable 1:	Variable 2:	Variable 3:	Variable 4:	Variable 5:
Channel 1	House	Up= 100%	Down= 0%	Mid 1= 50%	Mid 2= 50%
Channel 2	House	Up= 100%	Down= 0%	Mid 1= 50%	Mid 2= 50%
Channel 3	Stage	Up= 100%	Down= 0%	Mid 1= 50%	Mid 2= 50%
Channel 4	Stage	Up= 100%	Down= 0%	Mid 1= 50%	Mid 2= 50%

## Zone Name:

0	None
1	House
2	Stage
3	Zone 3
4	Zone 4
5	Zone 5
6	Zone 6
7	Zone 7
8	Zone 8
9	Zone 9
10	Zone 10
11	Zone 11
12	Zone 12
13	Zone 13
14	Zone 14
15	Zone 15
16	Zone 16

**3-Sound**

Parameter:	Value:
RVC 5	Disabled
Output 1	Dolby CP65
Output 2	Dolby CP65

***The States of “No-Op” and “None”:***

Although the No-Op and None states would seem to do similar things, they actually behave quite differently. No-Op can be thought of more accurately as “No-Change” and None, more like “All Off” The way each of these works is slightly different depending on what it is being used for.

**Power Up States**

The eCNA Automation remembers its current state for its outputs even when power is lost. This gives the eCNA automation the ability to return to its previous state when power is re-applied.

**No-Op**

When the power up state is set to No-Op, the eCNA will return the outputs to their previous state before the power loss. For maintained outputs this means engaging the relays and for the pulsed output the relays are pulsed.

#### None

When the power up state is set to None, the eCNA will do nothing on power up. It also sets its internal state for these outputs to none. For maintained outputs the relays remain off, and for pulsed outputs, there is no pulse.

#### **Fault to states**

#### No-Op

When the Fault-To state is set to No-Op, the eCNA will not change the relay states on a fault. For maintained outputs the relays will not change, For the pulsed outputs, no relays will pulse.

#### None

When the Fault-To state is set to None, the eCNA will turn off all outputs. It also sets its internal state for these outputs to none. For maintained outputs the relays are turned off, for pulsed outputs the relays are not pulsed.

## Index:

“Static IP”	20
10Base-T	18
Alarm Cancel	5
Alarm Loudness	22
Booth termination Panel	7
Check Focus Alarm	12
Check Focus delay	12
CineNet Driver	30
CineNet Host	29
CineSuite	30
CineSuite Manager	30
CNA Programming	23
Console Termination Panel	6
Copy Functions	29
Cue Input	6
Cue Number	4
Curtain Call key	24
Description	3
DHCP	20
“Dumb-Terminal”	14
Edit	5
Ethernet	18
Ethernet configuration menu	14
Fault Conditions	26
Fault defeat	5
Gateway IP.	16
HTML-Based Configuration	16
Interface Hardware	18, 20
Intermission Key	24
Introduction	1
IP	16
IP configuration	17
Keypad	4
LAN	16
LIN, Description	3
Local Area Network	16
Loop Number	5
LSN, description	3
MAC ID	17
Manual Overrides	26
Memory Faults	27
Operating the eCNA-100	25
Operator Interface	3
Overview	2
P8	18
PCI-64 network interface	29
Power-Up messages	29
Program Number	4
RJ45	14



Router .....	10
RS-232 serial port .....	18
Run-Time Faults .....	27
Setup .....	23
Software Revision History .....	36
Start .....	5
Static IP .....	20
Status LED's .....	5, 22
Stop .....	5
Subnet mask .....	16
Supervisory .....	29
Switch Configuration .....	8
Sync .....	5, 26
Sync Failsafe Fault .....	28
Synchronous operation .....	26
TCP Host .....	13
TCP/ IP Networking .....	20
Termination Panel, Booth .....	6
Termination Panel, Console .....	6
Timing Diagrams .....	31
VNC .....	29

## List Of Illustrations:

- Figure 1: eCNA Front Panel Illustration  
Figure 2: eCNA-100 DIP Switch Configuration  
Figure 3: LSN Dip Switch ID configuration table  
Figure 4: RS-232 TCP/IP configuration screen  
Figure 5: Embedded TCP/IP Configuration welcome screen  
Figure 6: Embedded TCP/IP Configuration Status screen  
Figure 7: Embedded TCP/IP Password screen  
Figure 8: Embedded TCP/IP Set-Up screen  
Figure 9: Mainboard Port Illustration  
Figure 10: TCP/IP network example  
Figure 11: Network status LED's/ Alarm volume jumpers
- Timing Diagram 1: Standard Operation  
Timing Diagram 2: Fault Stop Shutdown and Restart sequence  
Timing Diagram 3: Intermission Stop sequence  
Timing Diagram 4: Curtain Call sequence

**(e)CNA-100 Major replacement parts:**

Below is a listing of the major components that make up the eCNA. Use this table when ordering replacements or inquiring about repairs.

Part Description	Strong P/N	OEM P/N
CNA Power Supply PC Board	5198304	39328
CNA Power Transformer		64011
DPST Rocker Switch, Power and Overrides		39336
SPDT Rocker Switch, Overrides		39337
SPDT Rocker Switch, Overrides		39338
DC Power Harness (Power supply to CPU board)		39309
Piezo Transducer (Alarm)		39307
eCNA CPU Board		39425-1
CNA-100 Display PCB	5172009	39326
CNA-100 Front Panel (Keypad Overlay, Switches and Metal)		39310