

# CNA-150 Automation

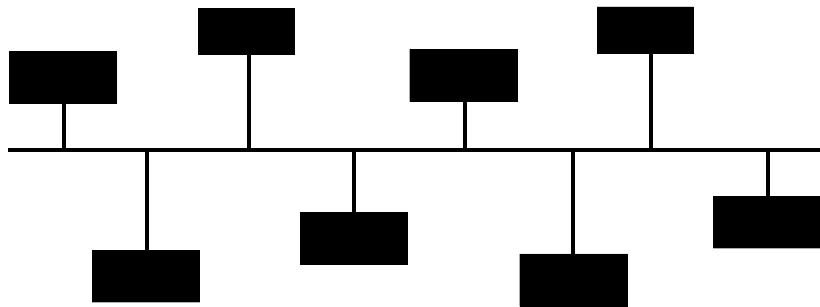

## Setup and Operation Manual



Revision 200  
March 2005



# **CNA 150 Automation**

## **Setup and Operation Manual**

### **PR003      Revision 2**

---

This manual covers the setup and operation of CNA-150 automation system.

Optional CineNet and related equipment is covered in the following product reference manuals:

- PR001 CNA Installation Manual
- PR002 CNA-200 Setup and Operation Manual
- PR003 CNA-150 Setup and Operation Manual
- PR004 CNA-100 Setup and Operation Manual
- PR005 QDC-400 Installation and Setup Manual
- PR006 ACP-50 Installation and Setup Manual
- PR007 RVC-5 Installation and Setup Manual
- PR008 PCI-64 Gateway Interface Installation
- PR009 CineNet Host Software
- PR010 RCM-10/RSM-10/RSM-20 Installation and Operation Manual
- PR011 Strong Dimmer Installation, Setup, and Operation Manual
- PR012 eCNA-100 Automation Manual
- PR013 eCNA-150 Automation Manual
- PR014 eCNA-200 Automation Manual
- PR016 Strong FP350 Installation and Operation Manual
- PR017 Eprad FP350 Installation and Operation Manual
- PR018 Paging system Setup and Installation Manual
- PR019 VNC Setup and Operation Manual
- PR020 CineSuite Installation and Operation Manual

---

### **Warranty**

CineNet automation products, sold by STRONG INTERNATIONAL, are warranted against defects in materials and workmanship for one year from the date of purchase. There are no other express or implied warranties and no warranty of merchantability or fitness for a particular purpose.

During the warranty period, STRONG INTERNATIONAL will repair or, at its option, replace components that prove to be defective, provided the unit is shipped prepaid to the manufacturer directly or via an authorized distributor. Not covered by this warranty are defects caused by modification, misuse or accidents and any further damage caused by inadequate packing for service return.

STRONG INTERNATIONAL's obligation is restricted to the repair or replacement of defective parts and under no circumstances will STRONG INTERNATIONAL be liable for any other damage, either direct or consequential.

---

Information in this document is subject to change without notice. No part of this document may be reproduced or transmitted in any form or by any means, electronic or mechanical, for any purpose, without the express written permission of STRONG INTERNATIONAL.

© 1997 - 2005 STRONG INTERNATIONAL. All rights reserved.



# Table of Contents:

- Introduction** ..... 1
- Section 1** ..... 2
  - System Overview ..... 2
    - Product Description ..... 3
    - Local I/O Network (LIN) ..... 3
    - Local Synchronous Network (LSN) ..... 3
  - System Components ..... 4
    - Control Panel (Operator Interface) ..... 4
    - Termination Panels ..... 7
      - Dual Termination Panels ..... 8
      - Console Termination Panel ..... 8
      - Booth Termination Panel ..... 9
      - Single Termination Panel ..... 10
- Section 2** ..... 11
  - Setup ..... 11
    - DIP Switch Settings ..... 11
      - Switch Definitions ..... 12
    - Alarm Loudness setting ..... 16
    - Status LEDs ..... 16
  - Checking the Network ..... 17
  - Menu Structure ..... 19
  - Setup Supervisory ..... 22
  - CNA System ..... 23
  - Setup Dimmer ..... 27
  - Setup Learn Times ..... 28
  - Network Status ..... 30
  - Copy ..... 32
    - Network Copy ..... 32
    - Local Copy ..... 33
  - Control ..... 34
  - Programming the CNA-150 ..... 36
  - The INTERMISSION and CURTAIN CALL Keys ..... 38
- Section 3** ..... 40
  - Operation ..... 40
    - Operating the CNA-150 ..... 40
    - Soft Manual Overrides & LEDs ..... 40
    - “Next State” feature ..... 40
  - Check Focus Alarm ..... 41

Cue Learn Function .....	41
Cue Window Factor .....	42
Synchronous Operation .....	44
System Status Messages .....	45
Fault Condition Messages .....	45
Memory Faults .....	45
Program Memory Fault .....	45
Set-Up Parameters Memory Fault .....	46
Synchronous Interlock Faults .....	47
Local Faults .....	49
Status Messages .....	50
Power Up Messages .....	51
<b>Timing Diagrams for the CNA-150</b> .....	<b>53</b>
<b>Addendum</b> .....	<b>59</b>
Software Changes .....	59
<b>Index</b> .....	<b>67</b>
<b>List of Illustrations</b> .....	<b>68</b>

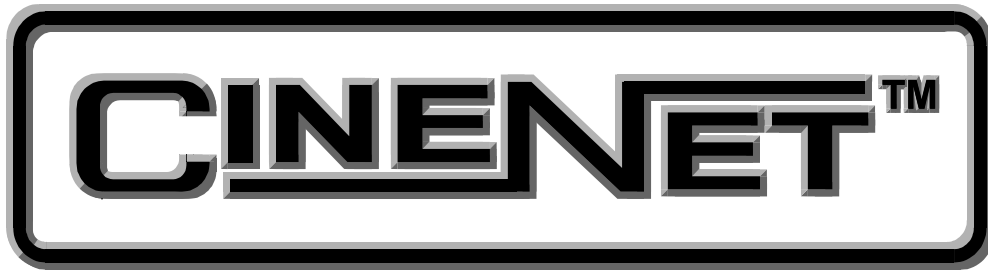

An Introduction to  
**THE CINENET™ SYSTEM**

Strong International's CINENET™ is an automation and control network designed specifically for the Motion Picture Theatre Industry. CINENET™ provides a low cost connection to various control and I/O devices in the projection booth, auditorium, and throughout the theatre complex. CINENET™ is divided into two network layers: The Local Synchronous Network (LSN) is a complex-wide data network that provides advanced synchronous projector control, user selected data transfer and real-time remote automation status. The Local I/O Network (LIN) is designed to provide remote I/O control for each screen in a complex. The CINENET™ network offers many advantages over point-to-point wiring such as reduced installation costs, reduced wiring errors and high noise immunity. CINENET™ also allows management to program and access real-time status of all auditoriums in the theatre complex from a central location using a personal computer. Strong will continue to develop new CINENET™ products that will provide the control and flexibility the theatre industry demands.

## **Section 1**

### **SYSTEM OVERVIEW**

The CNA-150® Cinema Network Automation is a CINENET™ compatible automation system specifically designed for the Motion Picture Theatre industry. The system is modular in design, consisting of the operator interface and system peripherals. The Main Computer and each peripheral device is defined by its common functions and locations in the booth. The devices within the system communicate with each other on a serial communications link. Automation systems and remote stations distributed throughout the booth and other areas of the multiplex communicate on a second serial communications link.

The CNA-150 operator interface is user-friendly and intuitive. Once some basic rules are learned you will be programming and running basic programs in less than an hour.

To enhance the operation of the CNA-150 and provide a higher level of control, the CINENET™ Gateway PC Card and Host software is available. This product will provide a PC interface to the CNA-150 automations. The Host PC and software will allow management to access programming, data logging and diagnostic information from all systems connected to the network. Access to data and system upgrade software will also be available via the modem/Internet.

This manual provides the installer and user with the necessary information to install, setup and operate the CNA-150 automation system. The installer is encouraged to read all sections of the manual before proceeding with the installation. If while installing or operating the CNA-150 automation you find any part of the manual to be unclear or incorrect, please let us know. Call STRONG INTERNATIONAL at (800)-424-1215 if help or additional information is required.



## Product Description

The CNA-150 Cinema Network Automation System is a microprocessor based computer automation designed to automate all aspects of the theatre presentation. The Automation Network is briefly described below.

### Local I/O Network (LIN)

Each system component is connected to the network and communicates via a five wire (data+, data-, power, ground, and shield) cable. This cable provides the serial data and power to the termination panels. This is called the "Local I/O Network" or "LIN". The standard devices that make up the system are the:

1. Termination Panel(s)
2. CNA-150 Control Panel

The CNA-150 Automation Control Panel contains the Main or Master Computer of the system and each I/O device is connected to it via a serial communications link. The devices are connected in a "daisy-chain" method and can then be distributed within the booth according to their logical location.

### Local Synchronous Network (LSN)

The "Local Synchronous Network" is a three-wire (data+, data-, and shield) data link that will support CNA-150, CNA-100 and CNA-200's, remote stations, synchronous communications for interlock, network copy functions and a Host PC. The automation systems are connected together in a "daisy-chain" configuration, which allows the transmission line to continue from one unit to the next.

## System Components

The standard components that make up the automation system are described in the following sections.

### Control Panel (Operator Interface)

The automation controller and front panel interface is a standard 19" rack mount cabinet. The cabinet can be mounted in all Strong Console systems. The unit will house the main CPU, the front panel interface and the power supply for local and remote power for the Local I/O Network.

Communications to the local I/O devices and other remote CNA-150 systems is accomplished via two serial ports on the Main CPU:

*The Local I/O Network (LIN) Com Port* - This is the interface for the Local I/O Network that will support the Main I/O Interface, the Console and Booth Termination Panels and other auxiliary devices.

*The Local Synchronous Network (LSN) Com port* - This is the interface for the Interlock and Copy function between CNA-150 systems, Remote Monitors and PC Host.

The front panel is used to setup, program and run the shows. It also displays error and status messages to the user. The front panel incorporates nine manual override switches used for emergency manual control. These are rocker type switches and their general functions should be obvious to the operator. All manual controls circumvent the electronic circuitry giving the user the ability to control most major functions in the event of an automation failure. The manual control functions are listed below:

1. PROJECTOR - Maintained ON/AUTO
2. LAMP - Maintained
3. CHANGEOVER - Momentary OPEN/CLOSE
4. LENS & MASKING - Momentary FLAT/SCOPE
5. LENS & MASKING - Momentary SPECIAL
6. CURTAIN - Momentary OPEN/CLOSE
7. HOUSE LIGHTS - Momentary UP/DOWN
8. STAGE LIGHTS - Momentary UP/DOWN
9. AUXILIARY - Momentary ON1/ON2

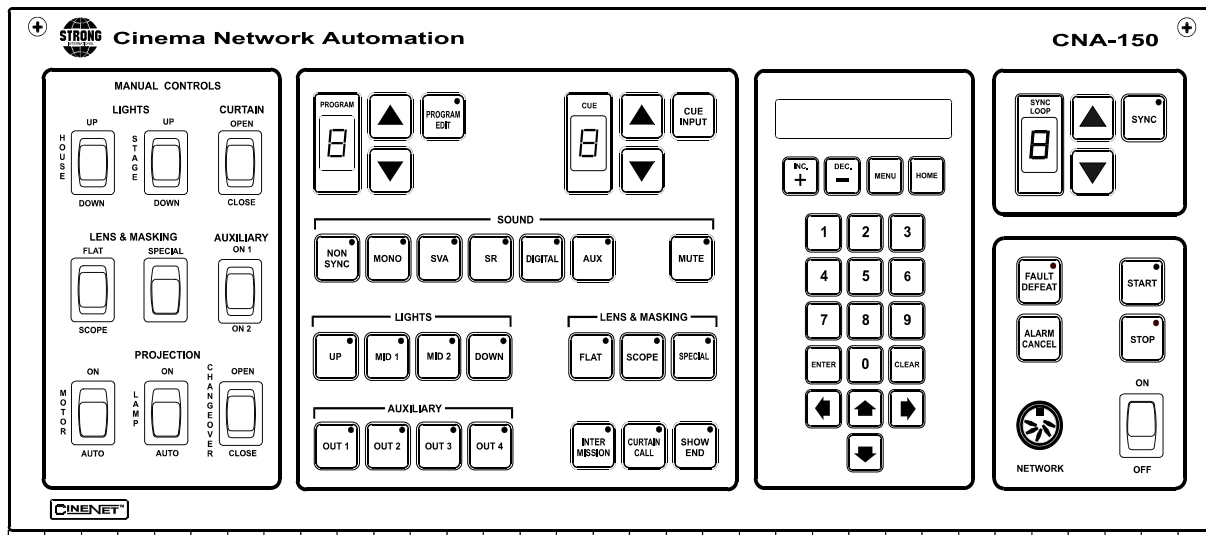

Figure 1

### Program Number

Displays the program number to run or edit. Use the up and down cursor keys to select the program number. Up to nine unique programs can be saved.

### Cue Number

Displays the show cue number. During programming use the up and down cursor keys to select the cue number to edit. Up to nine cues can be programmed for a show.

### Programming Keys

These keys are used to program the sound, lens, masking, lights, intermission, curtain call and end of show. LEDs are on each key. The LED is "on" indicating the present state of the output during a show.

### Program Edit Key

This key is used to enter the program edit mode allowing the user to build new or alter existing programs. The LED is on when "program edit" is active. The user may edit any program during a show or between shows.

### Start Key

This key is used to start or restart a show. The LED on the start key will "blink" when the show is *ready to start* or *ready to restart*. The LED is "on" when the show is running, and "off" when the show is stopped.

**Stop Key**

This key is used to stop a show. The LED on the stop switch is "on" when a show is stopped, due either to a "local" or "remote" stop input or a fault.

**Sync Key**

This key is used to activate the automation for synchronous (interlock) operation. The sync LED will be "on" indicating the automation is in sync mode.

**Sync Loop Number**

This displays the Sync Loop number. Use the up and down cursor keys to change the loop number. Up to 9 different loops can be on the sync network. 0 disables the machine from sync operation. The user is prevented from changing the Sync Loop number when sync is enabled with the Sync Key.

**Power Switch**

Supplies power to the automation main controller and termination panels.

**Fault Defeat Key**

This key will defeat or bypass the fault inputs (film presence, film motion and xenon lamp). This key is normally used for testing the projection equipment or newly edited programs. It is *not* recommended for normal operation. The LED will "blink" when the Fault Defeat is activated.

**Alarm Cancel Key**

This key will cancel the local alarm and all remote alarms. This key is also used to clear any of the latched faults. Pressing the Alarm Cancel key once will cancel the alarm. Pressing the key again will clear the fault condition.

**Cue Input Key**

This key provides a manual cue input. This is similar to the cue input from the electronic cue detector or pick off. This key is always active during a show.

**Numeric Keypad and Display**

The keys and display are used to setup system parameters and view diagnostic and run-time status. The display also indicates local and remote faults.

## Termination Panels

The CNA Control Panel currently supports two types of termination systems. The type used depends on the specific requirements of the projection booth designers.

The **Dual** termination system consist of two panels that support all standard console and booth equipment control I/O. The functions are logically divided between the two boards according to the location of the projection booth equipment. The *Console* termination panel controls the equipment that is normally associated with the console system such as the projector, lamp, film monitoring, etc. The *Booth* termination panel controls other functions such as masking, curtains and lights. The Dual termination system is flexible in that it allows the Booth termination panel to be located in a place other than the console.

The **Single** termination system combines most of the functions of the Console and Booth Panels into a single panel. This panel provides an option of a single lower cost board for installations that do not need the functions on separate boards.

## Dual Termination Panels

### Console Termination Panel

This panel supports the input and output termination interface and provides connections for standard booth functions as listed below:

#### Outputs:

- Projector Motor; On/Off
- Xenon Lamp; On/Off
- Changeover; Open/Close
- Lens Turret; Flat/Scope/Special
- Slide Projector; On/Off

#### Inputs:

- Film Presence
- Film Motion
- Film Tension
- Cue Input
- Xenon Fault

#### Features:

- High power *dry* relay contact outputs.
- High power override connector for plug-in cable to override switches.
- Projector motor fuse.
- Plug-in I/O CPU Control Board to handle I/O and serial interface.
- Terminal Blocks for connection to the console equipment.

The relays and I/O CPU Control Board get their power from the network cable. The Control Board will plug onto the relay board to provide the I/O and network interface.

## Booth Termination Panel

This panel provides the outputs to control the following functions:

Outputs:

- Top Masking; Flat/Scope/Special
- Side Masking; Flat/Scope/Special
- Curtains; Open/Close
- House Lights; Up, Down, Mid 1, Mid 2
- Stage Lights; Up, Down
- Environment; On/Off
- Slide Projector; On/Off
- Sound Processor; Mono, SVA, SR, Digital 1, Aux, Nonsync

Inputs:

- Remote Start
- Remote Stop/Fire Stop

Features:

- Low power dry relay contact outputs.
- High power dry relay contact outputs for Slide Projector and Environment Control
- A plug-in I/O CPU Control Board to handle I/O and serial interface.
- Override connector for plug-in cable to override switches.
- Override connector for optional override switches.
- Large terminal blocks for user interface.

This Panel (PC board) will connect to the to the Local I/O Network (LIN). The outputs can be configured at the PC Host.

The relays and plug-in I/O CPU Control Board get their power from the LIN cable. This board will generally be mounted in a cabinet on the booth wall, but can also be mounted in the console next to the Booth Termination Panel.

## Single Termination Panel

This panel combines most of the functions of the Console and Booth Termination Panels. The connections and functions are listed below:

### Outputs:

- Projector Motor; On/Off
- Xenon Lamp; On/Off
- Changeover; Open/Close
- Lens Turret; Flat/Scope/Special
- Slide Projector; On/Off
- Masking; Flat/Scope/Special
- Curtains; Open/Close
- House Lights; Up, Down, Mid 1, Mid 2
- Stage Lights; Up, Down
- Sound Processor; Mono, SVA, SR, Digital, Aux, Nonsync, Mute

### Inputs:

- Film Presence
- Film Motion
- Film Tension/Remote Stop
- Cue Input
- Xenon Fault

### Features:

- Low power *dry* relay contact outputs.
- High power *dry* relay contact outputs.
- Override connectors for plug-in cable to override switches.
- Projector motor fuse.
- Changeover fuse.
- Plug-in I/O CPU Control Board to handle I/O and serial interface.
- Terminal Blocks for connection to the console and booth equipment.

The relays and I/O CPU Control Board get their power from the network cable. The Control Board will plug onto the relay board to provide the I/O and network interface.



## Section 2 SETUP

STOP - Please note at this point you should have completed the entire installation of the automation system. If you have not, go to the *Installation* manual and complete it before proceeding.

### DIP Switch Settings

The LSN can support up to 64 devices (CNA-100s, CNA-150s, CNA-200s, Remote Status Monitors and a Host Computer). **Each device will each require a unique Sync Id number.** Id 0 is reserved for the *Host PC* and Ids 1 through 63 are assigned to CNA-150s and other devices as necessary. To keep things simple, assign the CNA-150 Ids starting at 1, corresponding to the house number and working up. The Remote Monitor's Ids, if used, should be assigned to the higher numbers starting at 62 and working down. You may want to keep Id 63 reserved for the portable or *secondary* host.

To set the Id number, first locate the eight position dip switch designated S1. See figure 2.

### CNA-100/ 150 DIP Switch Settings

Current to Version 2.15/ 3.15

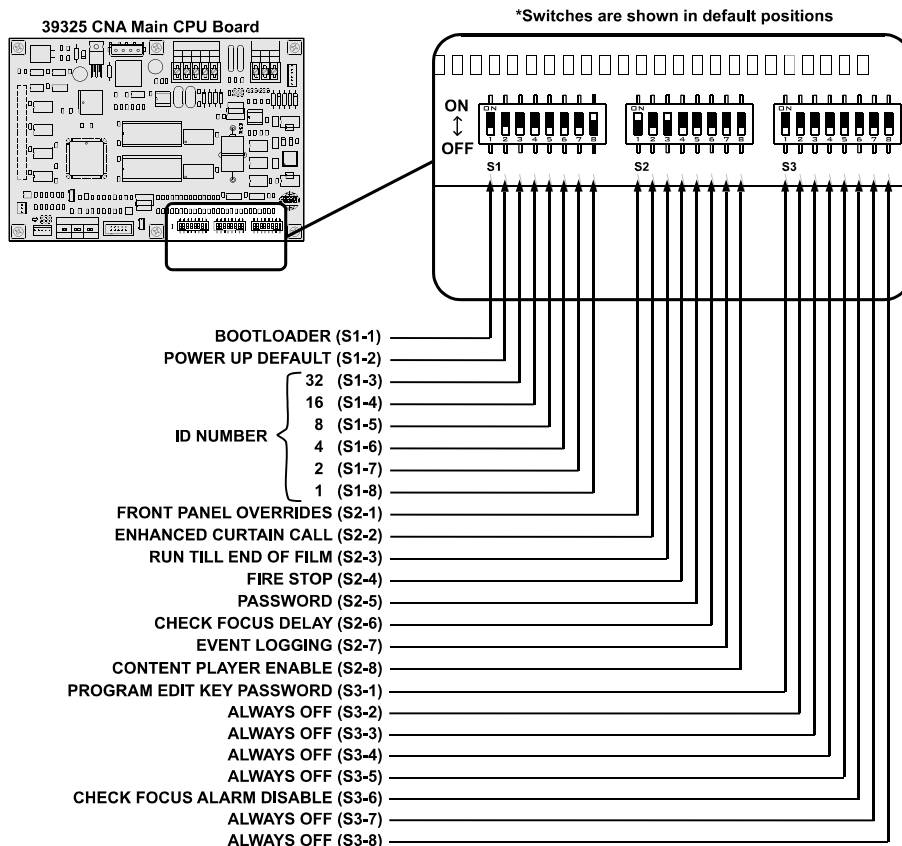

Figure 2

## Switch Definitions

### S1-1 Bootloader

On : Force Bootloader.

Off : Normal Use. (Factory Default)

Forces bootloader on power up in the event of a RTOS failure.

*Note:* Only versions 3.050 and above

### S1-2 Supervisory

On : Force “Supervisory Defaults” on power up. Default Supervisory data will be restored on each power up.

Off : Will **not** overwrite user-programmed supervisory data on power up. (Factory Default)

If you change any of the default settings with the Host program this switch must be off or the next time the CNA-150 is powered up all user settings will be overwritten with the defaults.

**S1-3** through **S1-8** are used to set the ID number. The number is represented as a 6-bit binary number which allows for 64 possible ID numbers (0-63). Do not use 0 (zero) as an ID number. It has been reserved for the PC Gateway Interface. Each bit (switch) has a decimal value. Add up the decimal values to get the ID number. For example, ID number 15 would be  $8+4+2+1=15$  or a DIP switch setting of 001111. See Figure 3.

**S1-3** On : 1 Decimal value = 32  
Off : 0 Decimal value = 0 (Factory Default)

**S1-4** On : 1 Decimal value = 16  
Off : 0 Decimal value = 0 (Factory Default)

**S1-5** On : 1 Decimal value = 8  
Off : 0 Decimal value = 0 (Factory Default)

**S1-6** On : 1 Decimal value = 4  
Off : 0 Decimal value = 0 (Factory Default)

**S1-7** On : 1 Decimal value = 2  
Off : 0 Decimal value = 0 (Factory Default)

**S1-8** On : 1 Decimal value = 1 (Factory Default)  
Off : 0 Decimal value = 0























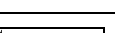
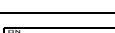
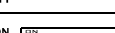
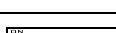
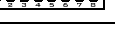
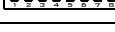
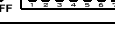
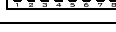



















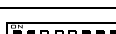
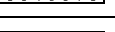
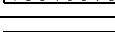
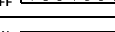
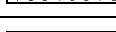









OFF=  ON= 	ID = 16 	ID = 32 	ID = 48 
ID = 1 	ID = 17 	ID = 33 	ID = 49 
ID = 2 	ID = 18 	ID = 34 	ID = 50 
ID = 3 	ID = 19 	ID = 35 	ID = 51 
ID = 4 	ID = 20 	ID = 36 	ID = 52 
ID = 5 	ID = 21 	ID = 37 	ID = 53 
ID = 6 	ID = 22 	ID = 38 	ID = 54 
ID = 7 	ID = 23 	ID = 39 	ID = 55 
ID = 8 	ID = 24 	ID = 40 	ID = 56 
ID = 9 	ID = 25 	ID = 41 	ID = 57 
ID = 10 	ID = 26 	ID = 42 	ID = 58 
ID = 11 	ID = 27 	ID = 43 	ID = 59 
ID = 12 	ID = 28 	ID = 44 	ID = 60 
ID = 13 	ID = 29 	ID = 45 	ID = 61 
ID = 14 	ID = 30 	ID = 46 	ID = 62 
ID = 15 	ID = 31 	ID = 47 	ID = 63 

Figure 3

## S2-1 Front Panel Overrides

On : Enable front panel overrides. The Sound, Lights, Lens/Masking and Auxiliary front panel switches will override the outputs without affecting the program. The next instruction will override any manual changes. (Factory Default)

Off : Disable front panel overrides. The Sound, Lights, Lens/Masking and Auxiliary front panel switches are only used for programming.

## S2-2 Curtain Call

On : Enables the enhanced Curtain Call function and overrides the original Curtain Call function. Place the Curtain Call cue at a distance before the next cue that is equal to the curtain close time. When the CNA-150 sees the Curtain Call cue, the curtains begin to close, the changeover closes and sound is muted. At the next cue, the curtains will begin to open. After the CURTAIN CLOSE TIMER counts down to zero, the curtain will be fully open and the changeover will open and the sound is selected.

Off : Original Curtain Call function. (Factory Default)

### S2-3 Run Til' End of Film

- On : Enables the “Run til End of Film” function. This overrides the normal 7 second motor off delay. The projector motor will run until the film runs out of the failsafe. (Factory Default)
- Off : Disables the “Run til End of Film” function. The projector motor will shut off after the normal 7 second delay.

### S2-4 Fire Stop

- On : Enables the “Fire Stop” function.

*39331 Booth Termination Board* - Converts the Remote Stop input to a Fire Stop input and the Slide Projector relay (K13) to a Fire Stop output. Fire Stop *acts* like a Remote Stop with the following exceptions:

- Sound is Muted.
- Slide Projector on *39330 Console Termination Board* is turned off *or* held off.
- K13 relay (Slide Projector) on Booth Termination board is turned on.

*39332 Termination Board* - Remote Stop input must be enabled on board. (W1-OPT1 jumper across pins 2 and 3 changes the Film Tension input to a Remote Stop input.) Converts the Remote Stop input to a Fire Stop input. Fire Stop *acts* like a Remote Stop with the following exceptions:

- Sound is Muted.
- Slide Projector is turned off *or* held off.

- Off : Disables the “Fire Stop” function. (Factory Default)

### S2-5 Password

- On : Requires use of the password to access many of the functions. (Factory Default)
- Off : Disables the password. No password is required to access the functions.

*Note: Version 3.030 and later.*

*Host & Local software defeat of this switch's function for versions 3.15 and up.*

### S2-6 Check Focus Delay

- On : Enables the “Check Focus Delay” function. In Clock Start or Timed Start the alarm will sound prior to the show starting. (Factory Default)
- Off : Disables the “Check Focus Delay” function.

The Check Focus feature alerts the operator that the show is about to start. In Timed Start the alarm will begin to sound 7 seconds prior to the show starting. This gives the operator time to make any quick adjustments and to insure the image on the screen is in focus.

*Note: Version 3.030 and later.*

**S2-7 Event Logging**

On : Enabled - Events are sent to the Host computer.  
Off : Disabled - Events are not sent to the Host computer.  
(Factory Default)

*Note: Version 3.040 and later*

**S2-8 Content Player**

On : Enable  
Off : Disable (Factory Default)  
Enables/ Disables digital content player communications, this function allows integration of a digital content player into the CNA network.  
*Version 3.090 and later \* See CAI user Guide*

**S3-1 Program Edit Key Password**

On : Enable Password required to edit but not to view programs  
Off : Disable No password required (Factory Default)  
“View only” mode indicated by Program Edit LED Flashing  
*Only available for versions 3.11 and up*

**S3-6 RCM/RSM-10 “Check Focus Alarm”**

On : Enable the RSM/RCM-10 Alarm  
Off : Disable the RSM/RCM-10 Alarm (Factory Default)  
*Version 3.15 and Up only*

**S3-2 to S3-5 Always OFF (Factory Default)**

Switches are undefined and should remain in their “OFF” positions

## Alarm Loudness setting

The alarm loudness can be set for one of three intensities; LOW (87 dBA), MEDIUM (94 dBA), HIGH (98 dBA). See figure 4 below.

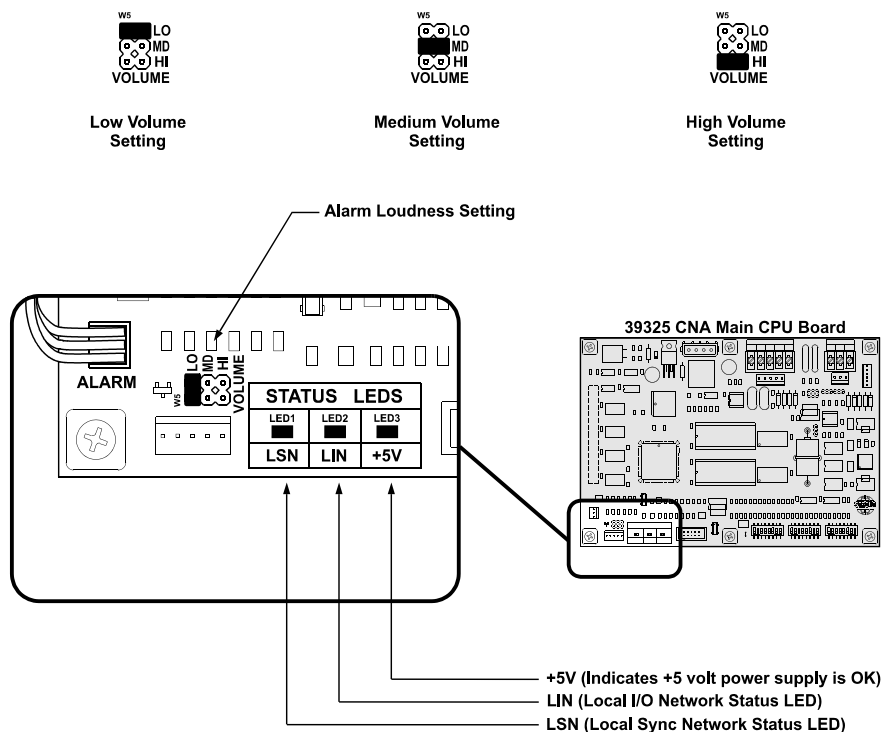

Figure 4

## Status LEDs

There are three status LEDs on the 39325 Main CPU Board. These indicate the status of the +5 volt power supply, the LSN and the LIN. Following are the three conditions for the LIN and LSN LEDs:

*Fast Blinking Rate:* The CNA-150 computer is working and is communicating properly.

*Slow Blinking Rate:* The CNA-150 computer is working, but is *not* communicating.

*Off:* The CNA-150 computer has a problem.

## Checking the Network

Once the CNAs are completely installed, it will be necessary to verify that all CNAs, Termination Panels and any other CINENET™ devices are communicating properly on their networks. The CNA-150 features two network status screens that display all devices on both the LSN and LIN networks.

From the CNA-150 front panel press: [MENU][2][1]. This is the LSN Status screen. This screen allows you to see all CNAs, Remote Monitors and Host PCs on the network. The first screen shows Ids 0 through 4 and the Sync Loop number for each.

```
Id    0 - 4  Loop#  
0    3  3   .   .
```

The bottom line of the display shows the Sync Loop numbers for each Id. For example, if the bottom line shows: **0 3 3 . .**, Id 0 is the Host computer, Ids 1 and 2 are on sync loop 3, and Ids 3 and 4 are not responding. Scroll down to see more Ids. The next screen will show Ids 5 through 9 and so forth. Sync loop “0” indicates that the CNA is present and responding correctly, but is not enabled for sync. If a device (CNA, Host, etc) is not showing a loop number, be sure the device is powered up and the Id is set correctly.

Next, verify the LIN devices by pressing [MENU][2][2]. This is the LIN Status screen. This displays all I/O devices detected by the CNA and lists them in order of Id number. For example, the Console Termination Panel detected is Id number 1 and is running version 3 software, checksum 150.

```
ID= 1 Console  
V   3 150
```

Following is a list of I/O devices currently supported by the CNA-150.

ID=1	Console	:	Console Termination Panel #1
ID=2	Console	:	Console Termination Panel #2
ID=3	Booth	:	Booth Termination Panel
ID=4	Aux I/O	:	Auxiliary I/O Board #1
ID=5	Aux I/O	:	Auxiliary I/O Board #2
ID=6	Aux I/O	:	Auxiliary I/O Board #3
ID=7	Aux I/O	:	Auxiliary I/O Board #4
ID=8	MCD-35	:	Film Monitor and Cue Detector #1
ID=9	MCD-35	:	Film Monitor and Cue Detector #2
ID=10	ACP-50	:	Auxiliary Control Panel #1
ID=11	ACP-50	:	Auxiliary Control Panel #2
ID=12	RVC-10	:	Remote Volume Control (analog & digital)
ID=13	QDC-400	:	Quad Dimmer Control Board
ID=14	QDC-400	:	Quad Dimmer Control Board
ID=15	QDC-400	:	Quad Dimmer Control Board
ID=16	QDC-400	:	Quad Dimmer Control Board

Note: The Single Termination Panel P/N 39332 is reported as both a Console and Booth.



## Menu Structure

The CNA-150 currently allows configuration and set-up of cue learn, timed start, local and remote copy functions, system timers, the QDC-400 dimmer control board and the RVC remote volume control. There are also LSN and LIN status screens that are useful for verifying network devices and diagnosing network problems. The set-up screens are broken down into menus and sub-menus that make it easy to locate the desired parameter. The structure of the CNA-150 menu is shown below.

### Main Run & Status Screen

#### Main Menu

#### 1 Set-Up

#### 1 Supervisory

#### 1 CNA System \*

#### 2 Dimmer

#### 3 Sound

#### 2 Learn Times \*

#### 3 Sound (v 3.14 and up)

#### 2 Network

#### 1 LSN Status

#### 2 LIN Status

#### 3 Copy \*

#### 1 Network Copy \*

#### 2 Local Copy \*

#### 4 Control \*

#### 1 Start Mode \*

#### 2 Cue Learn Mode \*

#### 3 Sound Level (v3.14 and up)

\* New in version 3.030

The menu is expanded showing all items. The editable parameters shown are factory defaults.

### Main Run & Status Screen

#### Main Menu

#### 1 Set-Up

#### 1 Supervisory

#### 1 CNA System \*

Sound Changeover Delay (sec) 7

Lens Changeover Delay (sec) 3

Lens Changeover Pulse (sec) .2

Failsafe Delay (sec) 2

Cue Factor Default .001\*

Cue Learn Mode Manual\*

Timed Start Disabled\*

Check Cue Fault Disabled\*

Missed Cue Fault Disabled\*

Rem Stop Alarm Time (sec) 10

Password Control Default^

Password xxxx

**2 Dimmer****Dimmer Ch1=House****Up 0% 0 sec****Down 0% 0 sec****Mid1 0% 0 sec****Mid2 0% 0 sec****Dimmer Ch2=Stage****Up 0% 0 sec****Down 0% 0 sec****Mid1 0% 0 sec****Mid2 0% 0 sec****Dimmer Ch3=None****Up 0% 0 sec****Down 0% 0 sec****Mid1 0% 0 sec****Mid2 0% 0 sec****Dimmer Ch4=None****Up 0% 0 sec****Down 0% 0 sec****Mid1 0% 0 sec****Mid2 0% 0 sec****3 Sound (V 3.14)****RVC-5 Disabled****Output 1 Dolby CP65****Output 2 Dolby CP65****2 Learn Times \***

<b>Program</b>	<b>(1-9)*</b>
<b>Cue 1 Time</b>	<b>0:00*</b>
<b>Cue 2 Time</b>	<b>0:00*</b>
<b>Cue 3 Time</b>	<b>0:00*</b>
<b>Cue 4 Time</b>	<b>0:00*</b>
<b>Cue 5 Time</b>	<b>0:00*</b>
<b>Cue 6 Time</b>	<b>0:00*</b>
<b>Cue 7 Time</b>	<b>0:00*</b>
<b>Cue 8 Time</b>	<b>0:00*</b>
<b>Cue 9 Time</b>	<b>0:00*</b>

**3 Sound Programs (v3.14 and up only)**

<b>Program</b>	<b>(1-9)</b>
<b>Cue 0 Level/Time</b>	<b>x.xdB/ 0:x</b>
<b>Cue 1 Level/Time</b>	<b>x.xdB/ 0:x</b>
<b>Cue 2 Level/Time</b>	<b>x.xdB/ 0:x</b>
<b>Cue 3 Level/Time</b>	<b>x.xdB/ 0:x</b>
<b>Cue 4 Level/Time</b>	<b>x.xdB/ 0:x</b>
<b>Cue 5 Level/Time</b>	<b>x.xdB/ 0:x</b>
<b>Cue 6 Level/Time</b>	<b>x.xdB/ 0:x</b>
<b>Cue 7 Level/Time</b>	<b>x.xdB/ 0:x</b>
<b>Cue 8 Level/Time</b>	<b>x.xdB/ 0:x</b>
<b>Cue 9 Level/Time</b>	<b>x.xdB/ 0:x</b>

**2 Network****1 LSN Status**

Id 0-4      Loop# .....  
 Id 5-9      Loop# .....  
 Id 10-14    Loop# .....  
 Id 15-19    Loop# .....  
 Id 20-24    Loop# .....  
 Id 25-29    Loop# .....  
 Id 30-34    Loop# .....  
 Id 35-39    Loop# .....  
 Id 40-44    Loop# .....  
 Id 45-49    Loop# .....  
 Id 50-54    Loop# .....  
 Id 55-59    Loop# .....  
 Id 60-63    Loop# .....

**2 LIN Status**

ID=1 Console  
 ID=2 Console  
 ID=3 Booth  
 ID=4 Aux I/O  
 ID=5 Aux I/O  
 ID=6 Aux I/O  
 ID=7 Aux I/O  
 ID=8 MCD-35  
 ID=9 MCD-35  
 ID=10 ACP-50  
 ID=11 ACP-50  
 ID=12 RVC-10  
 ID=13 QDC-400  
 ID=14 QDC-400 \*  
 ID=15 QDC-400 \*  
 ID=16 QDC-400 \*

**3 Copy \*****1 Network Copy \*****Type of Data \***

Supervisory Data \*  
 Learn Times (1-9) \*  
 Program (1-9) \*  
 All Programs \*

From ID: x

**2 Local Copy \***

Program (To/From 1-9, Default 1) \*

**4 Control \*****1 Start Mode**

Manual \*

**2 Cue Learn Mode**

Learn/Learned \*

**3 Sound Level**

(+10 to -50dB) (v3.14 and up)

\* Applies to version 3.030 and above

^ Applies to version 3.15

All menu items are preceded with a number. If you know the number of the menu item that you want to access, you may use only the number keys. For example, to access the Local Copy function from the main run screen press [3][2] and enter the password. Knowing the number sequence to the most frequently used functions can save considerable time.

Following are the number sequences to the most frequently used functions. This applies to version 3.030 and later.

CNA System	[MENU][1][1][1]	(Password Required)
Dimmer	[MENU][1][1][2]	(Password Required)
Learn Times	[MENU][1][2]	(Password Required)
LSN Status	[MENU][2][1]	
LIN Status	[MENU][2][2]	
Network Copy	[MENU][3][1]	(Password Required)
Local Copy	[MENU][3][2]	(Password Required)
Start Mode	[MENU][4][1]	
Cue Learn Mode	[MENU][4][2]	

## Setup Supervisory

The first step in the setup procedure is to configure the CNA-150 system parameters. Supervisory is used to customize the operation of the CNA-150. The CNA System menu contains a set of system parameters used to set system delays, timers, and other global attributes. The Dimmer menu allows configuration of the QDC-400 dimmer. And lastly the Sound menu provides access to control the RVC and select from popular sound processor output configurations.

## CNA System

The list below summarizes the CNA System functions. Defaults are shown.

Sound Changeover Delay (sec)	7
Lens Changeover Delay (sec)	8
Lens Changeover Pulse (sec)	.2
Failsafe Delay (sec)	1
Cue Factor Default	.001 *
Cue Learn Mode	Manual *
Timed Start	Disabled *
Check Cue Fault	Disabled *
Missed Cue Fault	Disabled *
Remote Stop Alarm Time (sec)	30
Password Control	Default^
Password	xxxx

\* New in version 3.030

Output Configuration can only be changed from the Host program. The relay output defaults are shown in the table below.

<u>Output</u>	<u>Contacts</u>	<u>Power-up</u>	<u>Fault-to</u>
Lens:	Pulsed	No-op	No-op ^
Masking:	Pulsed	No-op ^	No-op ^
Sound:	Pulsed	Non-sync ^	Non-sync ^
House Lights:	Pulsed	Up	Up ^
Stage Lights:	Pulsed	Up	Up^
Curtain:	Pulsed	None	No-op
Slide Projector:	Maintained	On	On
Out 1:	Pulsed	No-op	No-op
Out 2:	Pulsed	No-op	No-op
Out 3:	Maintained	No-op	No-op
Out 4:	Maintained	No-op	No-op

Items with a ^ are host-configurable for version 3.15 and up.

To enter CNA System , press [MENU][1][1][1]. At this point you will need to enter the password.

```
CNA Set-Up
ENTER PASSWORD
```

Sound Changeover Delay

```
Sound Changeover
Delay (sec)      7
```

The sound changeover delay determines the delay time between the show start input and the sound changeover from the *non-sync* music source.

For example, with the Sound C/O Delay set at 7, seven seconds after the show starts the changeover will open. And seven seconds after the last (end of show) cue is encountered the changeover will close. The legal range is 3 to 59 seconds. Enter data with the number keys.

**Lens Changeover Delay**

Lens Changeover Delay (sec)	8
--------------------------------	---

This represents the time required for the lens turret to change positions from flat to scope. It is the time the changeover will remain closed during lens changes. The result is a black screen. To determine the desired value, simply time the lens turret and add 1 second. The legal range is 0 to 9 seconds. 0 disables the function. Enter data with the number keys.

**Lens Changeover Pulse**

Lens Changeover Pulse (sec)	.2
--------------------------------	----

This setting controls the duration or width of the pulse sent to the changeover. It is recommended that the Changeover Pulse be set to the minimum value that allows the changeover to complete its full stroke. The legal values are .1 to 1.0 seconds. Enter data with the number keys.

**Failsafe Delay**

Failsafe Delay (sec)	1
-------------------------	---

This function is a film *bobble* delay designed to prevent premature shutdown caused by platter or other types of rewind and film transport equipment during startup or any other portion of the presentation. Any time the failsafe does not sense film presence during a presentation the Failsafe Delay timer is started, if film is detected before the timer expires, the presentation is not shutdown. If, however, film is not detected before the timer expires, the presentation is stopped and the alarm will sound. Legal entries range from 1 to 10 seconds. Enter data with the number keys.

**Cue Factor Default**

Cue Factor Default	.001
-----------------------	------

*Note: Version 3.030 and later.* This function is used in conjunction with CNA-150 *Cue Learn* system. The system learns the cue locations the first time a presentation is shown and places a “window”, based on the Cue Factor number. In the event of a missed cue, the CNA-150 maintains the proper timing of events by automatically inserting a cue at the end of the window.

Simply put, the cue window time is the *Cue Factor* multiplied by the *Cue Time*. For example, if The Cue Factor Default is .001 and the cue occurs 50 minutes into the presentation, the size of the window is:  $.001 \times 50 = .05$  minutes or  $(.05 \times 60)$  3 seconds. Remember, the time of each window is based on the distance the cue is from the beginning of the film. So it follows that the further the cue is from the beginning of the film, the larger the window will be. Based on this, select a Cue Factor you can live with. For an average length movie, a Cue Factor Default setting of .002 is good.

Legal range is .001 to .999.

*For more information see Cue Window Factor see Cue Learn Mode.*

**Cue Learn Mode**

Cue Learn Mode  
Manual

*Note: Version 3.030 and later.* This setting allows the Cue Learn Mode to be *manually* or *automatically* terminated at the end of the first presentation or *disabled*. In the Manual mode the operator is required to manually de-activate the Cue Learn Mode by pressing the Learn Mode key after the first presentation is completed. In the Auto mode the CNA-150 assumes that all cues were in their proper location and the presentation went as planned. At the end of the first presentation the CNA-150 will automatically de-activate the Cue Learn Mode. When Cue Learn Mode is disabled the operator is prevented from activating the “learned” mode. The entries are **Auto**, **Manual** and **Disabled**. Select the message with the [+] and [-] keys.

**Timed Start**

Timed Start  
Disabled

*Note: Version 3.030 and later.* This function controls access to the timed autostart function. The entries are **Enabled** and **Disabled**. When Timed Start is disabled the operator can not access the Time Start feature. Toggle the messages with the [+] and [-] keys.

**Check Cue Fault**

Check Cue Fault  
Disabled

*Note: Version 3.030 and later.* When using the system Cue Learn mode feature there is a fault message that is displayed after running the presentation in *Learn* mode. The message “CHECK CUE TIMES” is displayed as a reminder to the operator to verify the cue times after the first show. This message can be suppressed by setting it to Disabled. This message is also suppressed if Cue Learn Mode is set to Disabled. Toggle the message with the [+] and [-] keys. See also *Cue Learn Mode*.

**Missed Cue Fault**

Missed Cue Fault  
Disabled

*Note: Version 3.030 and later.* When using the system Cue Learn mode feature there is a fault message that is displayed after running the presentation in *Learned* mode. For example, the message “MISSED CUE 3” will be displayed if the system did not see cue foil 3 during the show. This message can be suppressed for those theatres that do not use cue foil on the film, or for some other reason do not want to see this fault message. Toggle the message with the [+] and [-] keys. See also *Cue Learn Mode*.

**Remote Stop Alarm Time**

Rem Stop Alarm Time (sec)	30
------------------------------	----

This function serves as a remote network alarm. When set to a non-zero time the alarm will pulse (for the programmed time) if another CNA automation on the network has faulted. Setting the time to 0 will disable this feature. Setting the time to 99 will sound the alarm until the alarm is canceled at the CNA that caused the fault or a Remote Monitor.

Set-Up CNA-100/150 System		10:56:02	5/ 3/2005	NET	2
Record Name:	PROJ100			MIN= 0	MAX=59
Sound C/O Delay (sec):	59			1 CURRENT RECORD	
Lens C/O Time (sec):	2			2 RECORDS USED	
ChangeOver Pulse (sec):	1.0			2 TOTAL RECORDS	
Failsafe Delay (sec):	4				
Cue Factor Default:	0.007				
Password:	Default 3141	Output	Contacts	Power-up	Fault-to
Cue Learn:	Auto	Lens:	Maintained	Special	Flat
Timed Start:	Enabled	Masking:	Maintained	Scope	Flat
Check Cue Fault:	Enabled	Sound:	Maintained	Dig 1	SUA
Missed Cue Fault:	Disabled	H. Lights:	Maintained	Mid 1	Mid 2
Time Format:	12Hr	S. Lights:	Maintained	Up	Up
Remote Stop Alarm (sec):	12	Curtain:	Maintained	Open	Open
Out 1 Controls:	Curtain Close	Slide Proj:	Maintained	On	On
Out 2 Controls:	House Mid 1	Out 1:	Maintained	On	On
Out 3 Controls:	House Mid 2	Out 2:	Maintained	On	On
Out 4 Controls:	Curtain Open	Out 3:	Maintained	On	On
		Out 4:	Maintained	On	On

Esc=Save Changes

**Additional CNA System Setup (Host Only)**

Additional CNA-150 parameters may be configured from the Host program. You must have a host computer running the CINENET™ Host program and the PCI-64 or PCI-64A Gateway Interface connected the LSN. The illustration above shows the CNA-100/150 Set-Up screen.

Relay outputs can be configured for pulsed or maintained, and fault-to and power-up conditions. You can also assign unused relays to the Out 1, Out 2, Out 3 and Out 4 controls. For example, if you are using the QDC-400 dimmer, there are 6 dimmer relays that will not be used. You may assign Out 1 to control the House Down relay and Out 2 to control the House Up relay. These outputs can then be programmed as part of a show.

See the *Host Program Operators Manual* for further information.



## Setup Dimmer

The QDC-400 Dimmer Control Board is required for this procedure. The CNA-150 and QDC-400 Dimmer Control board allow the user to configure lighting scenes in minutes.

Note: Before beginning be sure the QDC-400 Control board, dimmer power modules and lights are wired and tested.

Enter the dimmer set-up screens by pressing [MENU][1][2] (or by pressing [MENU][ENTER][▼][ENTER]). Enter the password to gain access.

```

  D i m m e r
  E N T E R   P A S S W O R D

```

The QDC-400 is a four channel dimmer and each channel must be appropriately set to either “House”, “Stage” or “None”. *Note: Any additional selections are only used for light show programs, which can only be programmed from the Host computer.* How these are configured will be determined by the physical wiring of the dimmer power modules and lights.

With the cursor on the channel field the press [+] or [-] keys to select the appropriate light zone. Repeat this for all channels and exit dimmer set-up to save zone data.

```

  D i m m e r   C h 1 = N o n e
  U p           0 %   0   s e c

```

Re-enter dimmer set-up by pressing [MENU][1][2].

But, before programming the levels and fade-in times you need to understand how the CNA-150 controls the House and Stage light zones. There are four *House* light levels that can be programmed from the front panel: UP, MID 1, MID 2 and DOWN. The *Stage* lights operate with the House lights as follows:

**When programmed for:**

**The lights do this:**

UP	:House Lights UP; Stage Lights UP
MID 1	:House Lights MID 1; Stage Lights DOWN
MID 2	:House Lights MID 2
DOWN	:House Lights DOWN; Stage Lights DOWN



Now you are viewing the *cue learn times* for the program.

```
Cue 0 Level/Time
      +10.0dB/0: 1
```

At this time you may enter or edit the cue learn times by using the number keys. Press the cursor keys or [ENTER] to move to different learn time fields. The learn times are displayed in minutes and seconds. The maximum value that can be entered is 999 minutes 59 seconds (equivalent to 16 hours 39 minutes and 59 seconds). Press the [CLEAR] key to reset the cue time to 0:00. Clear all cue times which are not being used. **Verify upon completion that all cue times are arranged in chronological ascending order.**

## Sound Programs

The sound programs submenu in the Set-Up menu allows the programmer to control supported device audio levels via an RVC in sync with program cues.

```
Program
                               1
```

Valid entries for the program number are 1-9 and the unit can be programmed to respond to cues 0-9 valid entries in the dB/Time fields are +/- 10dB and 0:00 to 0:10. This function is used for automating volume transitions during a presentation providing consistency between shows and eliminating the need for operator intervention.

```
Cue Learn Times
ENTER PASSWORD
```

*Note: Sound Programs only supported when using version 3.14 software and above*

## Network Status

The CNA-150 features two network status screens that display all devices on both the LSN and LIN networks.

From the CNA-150 front panel press: [MENU][2][1]. This is the LSN Status screen. This screen allows you to see all CNAs, Remote Monitors and Host PCs on the network. The first screen shows Ids 0 through 4 and the Sync Loop number for each.

Id	0	-	4	Loop#
0	3	3	.	.

The bottom line of the display shows the Sync Loop numbers for each Id. For example, if the bottom line shows: **0 3 3 . .**, Id 0 is the Host computer, Ids 1 and 2 are on sync loop 3, and Ids 3 and 4 are not responding. Scroll down to see more Ids. The next screen will show Ids 5 through 9 and so forth. Sync loop “0” indicates that the CNA is present and responding correctly, but is not enabled for sync.

Enter the LIN Status screen by pressing [MENU][2][2]. This displays all I/O devices detected by the CNA and lists them in order of Id number. For example, the Console Termination Panel detected is Id number 1 and is running version 3 software, checksum 150.

ID=	1	Console
V	3	150

There are seven fault messages that can be displayed to indicate a problem. The messages are:

```
DevErr
Commerr
TimeOut
"CAI COM TIMEOUT"*
"CP COM TIMEOUT"*
"CP NOT IN AUTO"*
"CP NOT READY"*
```

“DevErr” indicates that the CNA-150 does not recognize the remote device. This could be due to software version incompatibility. “CommErr” indicates that the remote device is not responding regularly. This could be due to a defective remote device or the wiring to it. “TimeOut” indicates a communication timeout condition, meaning that the remote device stopped responding after 5 seconds.

*\* For versions 3.09 and later. See CAI user guide for detailed information.*

Any of these faults will cause a “LIN: NETWORK FLT” message to be displayed on the top line of the display. Correct the problem and press the ALARM CANCEL key to clear message.

Following is a list of I/O devices currently supported by the CNA-150.

ID=1	Console	:	Console Termination Panel #1
ID=2	Console	:	Console Termination Panel #2
ID=3	Booth	:	Booth Termination Panel
ID=4	Aux I/O	:	Auxiliary I/O Board #1
ID=5	Aux I/O	:	Auxiliary I/O Board #2
ID=6	Aux I/O	:	Auxiliary I/O Board #3
ID=7	Aux I/O	:	Auxiliary I/O Board #4
ID=8	MCD-35	:	Film Monitor and Cue Detector #1
ID=9	MCD-35	:	Film Monitor and Cue Detector #2
ID=10	ACP-50	:	Auxiliary Control Panel #1
ID=11	ACP-50	:	Auxiliary Control Panel #2
ID=12	RVC-10	:	Remote Volume Control (analog & digital)
ID=13	QDC-400	:	Quad Dimmer Control Board
ID=14	QDC-400	:	Quad Dimmer Control Board
ID=15	QDC-400	:	Quad Dimmer Control Board
ID=16	QDC-400	:	Quad Dimmer Control Board

Note: The Single Termination Panel P/N 39332 is reported as both a Console and Booth.

## Copy

```

Transferring
Block 0 Pkt 0

```

*Note: Version 3.030 and later.*

The Copy function can be used to copy Programs or Supervisory data from another CNA-150. The copy function provides the option for a *Local* copy or a *Network* copy.

Local Copy is used to copy a Program from one location to another. For instance, you may want to copy Program #4 to Program #2 and edit it instead of starting a new program.

Network Copy is used to copy Programs or Supervisory data from a *remote* CNA-150. This further reduces the amount of data entry, particularly in large multiplexes. Using Network Copy you can only copy program data *from* a remote CNA-150 to the CNA-150 that is performing the copy. You are prohibited from copying *to* a remote CNA-150.

### Network Copy

To access the Network Copy screen press [MENU][3][1] and enter the password. The screen will prompt you to select the type of data you want to copy.

```

Type of Data
Supervisory Data

```

Scroll to the type of data you want to copy using the [+] and [-] keys. Below is a list of data types the CNA-150 can copy.

```

Supervisory Data
Learn Times 1 through 9
Programs 1 through 9
All Programs

```

Press [ENTER] and you are prompted to select a source Id. Select a valid Id number and press [ENTER].

```

From Id
1

```

Press [ENTER] again to perform the copy. The screen will display the data transfer status screen.

If the copy was successful, the screen will indicate this with a “Network Copy Complete” message. To perform another copy press any key (except for the [MENU] or [HOME] keys).

## Local Copy

To access the Local Copy screen press [MENU][3][2] and enter the password. The screen will prompt you to select the program number you want to copy.

```
From Local  
Default 1
```

“Default 1” is a canned program that can be copied to any other program. The Default 1 program is as follows:

Cue 1-8: Sound - Non-Sync  
Lights - Up  
Lens & Masking - Flat

Cue 9: Sound - Non-Sync  
Lights - Up  
Lens & Masking - Flat  
Show End

Scroll to the “source” program using the [+] and [-] keys and press [ENTER].

```
To Local  
Program 1
```

Scroll to the “target” program using the [+] and [-] keys and press [ENTER] again. Press [ENTER] one more time to perform the copy. If the copy was successful, the screen will indicate this with a “Local Copy Complete” message. To perform another copy press any key (except for the [MENU] or [HOME] keys).

## Control

*Note: Version 3.030 and later.*

This menu item contains special Control Modes for the CNA-150.

**Start Mode** allows the user to select either a Manual or Timed start. To select a start mode press [MENU][4][1].

```
Start Mode
          Timed
```

Press the [+] or [-] key to toggle between the “Manual” and “Timed” messages. Press [ENTER] to activate the start mode. When timed start is activated, the user is prompted to enter a time.

```
Start in 0:00
```

Enter a time with the number keys (minutes:seconds). Press [ENTER] to start the timer.

If Timed start is disabled in Supervisory, the operator is prevented from activating the Timed start mode.

The CNA-150 can either “learn” cues or use “learned” cues. When the CNA-150 is running a show in learned mode, it is using the cue times stored for that program. If the CNA-150 is running a show in learn mode, it is saving cue times for that program.

**Cue Learn Mode**, press [MENU][4][2].

```
Cue Learn Mode
          Learn
```

The [+] and [-] keys will select either “Learn” or “Learned” mode. Press [ENTER] to activate the cue learn mode. In learn mode an “L” will appear on the right side of the bottom line of the display.

If Cue Learn Mode is disabled in Supervisory, the operator is prevented from using the “learned” mode.



**Sound level** [MENU][4][3] The CNA-150 can control audio levels via an RVC. (Remote Volume Control) from +10.0dB to -50.0dB. Local control is possible when using this menu and the [INC+ and DEC-] keys on the front keypad. The numeric value on the display represents the gain/ attenuation level through the RVC.

```
Control Menu
3 Sound Level
```

```
Sound Level
          +10.0dB
```

*Note: Sound Level only supported in versions 3.14 and above*

## Programming the CNA-150

The CNA-150 is a *single cue* automation. This means that events, such as lens, masking and sound changes, are initiated by a cue (normally foil placed on the film). These events are stored in the CNA-150's memory and are called *programs*. The CNA-150 gives the user the ability to build and store up to nine different programs. Each Program can use up to nine cues. Programming is accomplished with the *Programming* keys and the *Program* and *Cue* numbers.

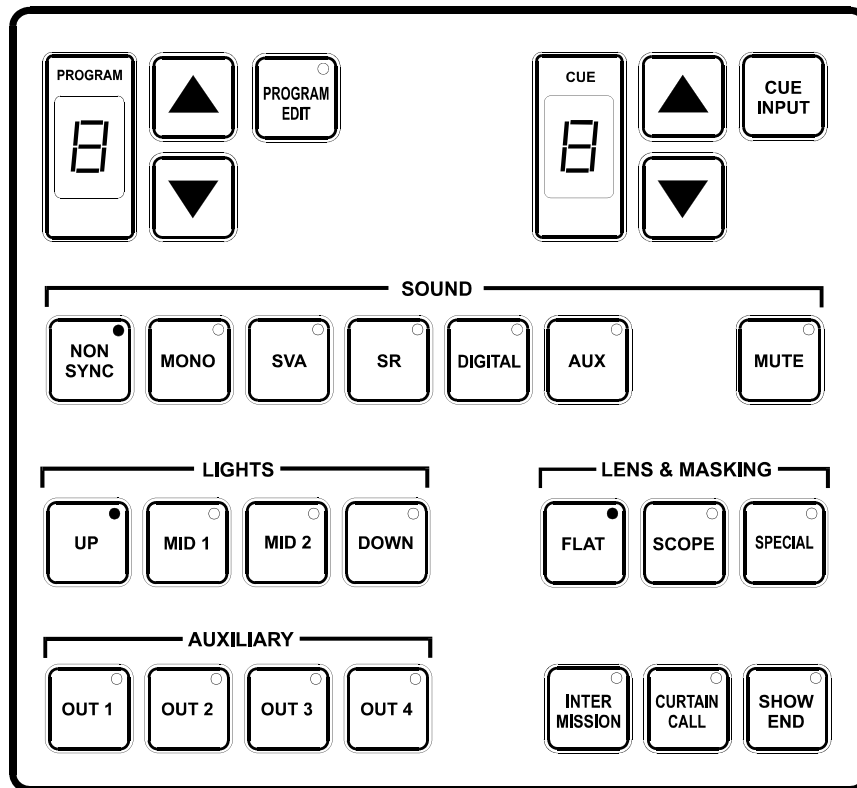

Figure 5

The following steps describe how to edit a program:

1. Press the PROGRAM EDIT key to activate the *edit mode*. The PROGRAM EDIT LED will toggle "on". The CUE up and down arrow keys are enabled and the PROGRAM and CUE displays will stop blinking *if* show is in progress.
2. Select the program to edit with the PROGRAM up or down arrow keys.
3. Program the Sound, Lens and Lights for each cue, starting at Cue 0, using the programming keys. Program the Auxiliary outputs (OUT 1 through OUT 4) if an 'Aux Board' is connected to the system or they are re-assigned to unused relays. (Note: This can only be done via the Host program. See the Set-up Supervisory section of this manual and *Host Program Operators Manual* for more information.) One or more of these outputs can be on at a time.

Note: Cue 0 is the *program start* cue. Cue 0 occurs at the “start” when *not* running in Sync mode and occurs at the “sync cue” when running in Sync mode. So, when programming remember Cue 0 is the first step of the program.

4. Use the SHOW END key to indicate the end of the program.
5. Select a different program to edit or press the PROGRAM EDIT key to deactivate *edit mode*. The PROGRAM EDIT LED will toggle "off". The PROGRAM number and CUE number *up* and *down* arrow keys will be disabled and the displays will slowly blink if the show is in progress.

Following are some simple rules to remember when programming:

Programming a SHOW END cue locks out subsequent cue numbers, keeping you from scrolling to a larger cue number.

You may edit any program while a show is in progress.

You may edit the program that is running, but you cannot change the number of cues.

When a show is in progress and you are *not* in the PROGRAM EDIT mode the PROGRAM and CUE number *up* and *down* arrow keys are disabled.

The LEDs on the programming keys reflect the program that is running, and do not show delays that effect the actual outputs.

## The INTERMISSION and CURTAIN CALL Keys

These are two special programming keys that allow the user to easily program a Show Intermission and a Curtain Call. The INTERMISSION key is used to program a show intermission at the selected cue. The cue then initiates the intermission sequence as follows:

Changeover Close  
Lights  
Sound  
Curtain Close

-----  
7 second delay  
-----

Xenon Lamp Off  
Projector Motor Off  
Slide Projector On

The Intermission is terminated and the show is re-started either by a START input (remote or local) or a CUE input (remote or local). If the show is re-started by a START input, only the projector motor and lamp are turned on. The next film cue will initiate the show start sequence. The show start sequence is as follows:

START

-----  
Xenon Lamp On  
Projector Motor On  
-----

Cue n

-----  
Lens/Masking  
Lights  
Curtain Open  
-----

7 second delay

-----  
Slide Projector Off  
-----

1 second delay

-----  
Changeover Open  
Sound

If the show is re-started with a CUE input, there is *no* need for a show start cue. The show start sequence is as follows:

```

CUE
-----
Xenon Lamp On
Projector Motor On
Lens/Masking
Lights
Curtain Open
-----
7 second delay
-----
Slide Projector Off
-----
1 second delay
-----
Changeover Open
Sound

```

The "Curtain Call" function will issue a curtain *close* at a selected cue. For example, suppose you wanted your curtains to close and the end of your trailers and open back up at the start of your feature presentation. You would place a cue at a distance before the end of the trailer that is equal to the curtain close time and another cue at the beginning of the feature. The sequence of events are as follows:

```

Cue n (with Curtain Call)
-----
Curtain Close
Sound (if programmed)
Lights (if programmed)
-----
Cue n+1
-----
Lens/Masking
Changeover Close
Lights
Curtain Open
-----
7 second delay
-----
Changeover Open
Sound

```

## Section 3

### OPERATION

#### Operating the CNA-150

In the "Ready to Run" state, the FILM PRESENCE LED will be "off", and the START LED will be blinking. Select the program 1 through 9, that you want to run with the up/down arrow keys. Press the START switch to start the show. The START LED will toggle "on".

When a show is running, the current states of the Sound, Lens, Lights and Auxiliary will be shown with the LEDs "on". The cue number displayed is the next cue the CNA-150 is waiting to see.

#### Soft Manual Overrides & LEDs

During run mode, pressing any of the Sound, Lens, Lights or Auxiliary keys will drive the output to that state. Note: This will not alter the saved program. At the next cue the program will override any manual changes.

The LEDs on the override keys reflect the program that is running, and do not show delays that effect the actual outputs.

#### “Next State” feature

Data entry key LEDs show the “next state” of the program. This feature allows the user to see the next programmed instruction without entering the Program Edit mode. The 3 conditions that can be observed from the switch LEDs are:

- a) LED On - This is the current state and the next state.
- b) LED On 1.8 sec : Off 0.1 sec - This is the current state; the next state is something else (including the *none*\* state).
- c) LED On 0.1 sec : Off 1.8 sec - This is the next state.

\* The “none” state is when none of the keys are programmed. This is not yet possible for the sound, lens & masking, and lights, but someday may be.

## Check Focus Alarm

*Note: Check Focus Alarm is supported in version 3.030 and later*

The Check Focus feature alerts the operator that the show is about to start. In Timed Start the alarm will begin to sound 7 seconds prior to the show starting. This gives the operator time to make any quick adjustments and to insure the image on the screen is in focus.

## Cue Learn Function

*Note: Cue Learn is supported in version 3.030 and later.*

The CNA-150 incorporates *cue learn* mode in which cues times for each program “learned” (or stored in memory). On subsequent runs the CNA-150 expects to see the film cues at a particular time. If a cue is not seen, due to a missing or worn cue foil, the CNA will automatically “issue” a cue which will advance the program and keep the show running properly. Cue Learn also makes it possible to operate a show without film cue foil at all!

Cue Learn is activated by the operator prior to running a film for the first time or after any change is made to the film itself (adding, deleting or moving cues). Using the internal clock, the CNA-150 will “learn” the cue times. After learning cue times all subsequent presentations will be run in the “learned” mode. The CNA-150 will expect to encounter these cues at particular times. If film cues are not encountered within a specified “window”, the system will automatically “insert” a cue allowing the program to carry out the next set of instructions. If any of the film cues are missed during a presentation an error message will be displayed at the end the show indicating which cues were missed. The size of the “window” is defined by the Cue Factor Default function in the Supervisory. Note that the Cue Input key on the control panel is always active. Cues can be input manually using the Cue Input key, or foil cues on the film can be sensed by the cue detector.

The Cue Learn function in the Supervisory can be set to Auto, Manual or Disabled. In the Auto mode Cue learn is automatically switched to “learned” after the first run of the program, after which all subsequent runs will be in the “learned” mode. In the Manual mode Cue Learn must be disabled manually by pressing the Cue Learn key. When set for disabled the cue learn function is not accessible.

## Cue Window Factor

The Cue Window Factor is a function of the cue times measured. Briefly, in Cue Learn Mode, the system measures the cue times produced using the film cue foils. Thereafter, if cues are missing, the system automatically supplies them. The width of the window is calculated using the Cue Window Factor and is *centered* around the normal cue time. Using this system, the projectionist does not have to be concerned about any missing or errant cues, once cues have been learned. The cue window is calculated to be sufficiently wide to accommodate any timing variations due to changes in motor speed caused by power line voltage or frequency fluctuations.

The Cue Window is calculated by the following equation:

$$\text{Cue Window} = (\text{CWF value}) \times (\text{cue location})$$

EXAMPLE: CWF value = 0.002, cue location = 2 hours

$$\text{Cue Window} = 0.002 \times 2 \text{ hours or } 120 \text{ minutes or } 7200 \text{ seconds}$$

$$\text{Cue Window} = 0.004 \text{ hours} = .24 \text{ minutes} = 14.4 \text{ seconds}$$

The Cue Window would be interpreted as follows. With a CWF value of 0.002, the CNA-150 would memorize the cue locations and wrap them in a 0.002 window. If an end cue was sensed at the 2 hour mark, the window would be 2:00:00 +/- 7.2 seconds for a total window of 14.4 seconds.

Illustrated it would look like this:

```

START                END CUE
|-----| 2:00:00
---> | <--- Cue Window of 14.4 seconds
starting at 1:59:52.8 and
ending at 2:00:07.2
    
```

Given a normal 2 hour presentation with four cues, we could establish a table indicating their respective time locations.

Name	Cue	Time from Start
Trailer	1	0:02:15
Show	2	0:06:32
Credits	3	1:48:26
End	4	2:00:00



Utilizing the same CWF value for each cue, the CNA-150 would construct a cue window table.

Name	Cue	Time from Start	Cue Window		
			Start	End	Size
Trailer	1	0:02:15	0:02:15	0:02:15	0.3 sec.
Show	2	0:06:32	0:06:31	0:06:33	0.8 sec.
Credits	3	1:48:26	1:48:13	1:48:39	13.0 sec.
End	4	2:00:00	1:59:53	2:00:07	14.4 sec.

Under normal conditions the CNA-150 will only recognize cues within the four established windows. If none are sensed it automatically inserts one at the end of a window which maintains your professional presentation. If cues are sensed outside the windows, they are assumed false and ignored.

The value of the cue window factor is determined by analyzing your local utility company's power fluctuations. This is done with the CNA-150. Simply keep the unit in the Cue Learn Mode for several days. After each presentation of the same show, record the cue values displayed in the Cue Learn setup screen.

To analyze the values, determine the maximum fluctuation in overall run time.

EXAMPLE:

#### LEARNED CUE VALUES

Cue	Show 1	Show 2	Show 3	Show 4	etc.
Cue 1	0:01:00	0:01:00	0:01:01	0:01:01	-----
Cue 2	0:04:00	0:04:00	0:04:01	0:04:01	-----
Cue 3	1:45:00	1:45:14	1:45:08	1:45:34	-----
Cue 4	1:55:00	1:55:16	1:55:09	1:55:36	-----

The widest fluctuation would be between shows 1 and 4. To estimate the CWF value, calculate the average fluctuation in run time by simply subtracting the low overall run time from the high overall run time (1:55:36 minus 1:55:00) and divide by 2. Then divide this number by the average run time [(1:55:36 + 1:55:00) divided by 2].

The result is as follows:

$$\begin{aligned}\text{Average fluctuation} &= (\text{HIGH VALUE} - \text{LOW VALUE}) \text{ divided } 2 \\ &= (1:55:36 - 1:55:00) \text{ divided by } 2 \\ &= (0:00:36) \text{ divided by } 2 \\ &= 18 \text{ seconds}\end{aligned}$$

The average run time is simply calculated as follows:

$$\begin{aligned}\text{Average run time} &= (\text{HIGH VALUE} + \text{LOW VALUE}) \text{ divided by } 2 \\ &= (1:55:36 + 1:55:00) \text{ divided by } 2 \\ &= 3:50:36 \text{ divided by } 2 \\ &= 1:55:18 \text{ or } 1 \text{ hour, } 55 \text{ minutes and } 18 \text{ seconds}\end{aligned}$$

The deviation is calculated as follows:

$$\begin{aligned}\text{Deviation} &= \text{AVERAGE FLUCTUATION} / \text{AVERAGE RUN TIME} \\ &= 0:00:18 / 1:55:18 \text{ (convert to seconds)} \\ &= 18 \text{ seconds} / 6918 \text{ seconds} \\ &= .002602\end{aligned}$$

Your Cue Window Factor should not be less than the deviation. In our example the Cue Window Factor should not be less than 0.003.

We recommend adding 0.002 to the calculated three digit value. In our example the value in three digits is 0.005. A logical CWF should be 0.005.

The CWF value of 0.005 is logical in light of actual conditions. If you find lights coming up early at credits, you may wish to open the credit window up with a larger value. Remember, every 0.001 equals an increase in the window size of 3.6 seconds for every hour of movie length.

Our investigation indicates that power fluctuations normally represent a speed fluctuation of less than 0.1 percent (CWF value of less than 0.002).

## Synchronous Operation

The CNA-150 systems are capable of running film synchronously in a multi-projector booth. The CNA-150 can be programmed for any one of nine sync loops. This allows for up to nine different sync loops on the network at one time. Pressing the SYNC key will activate the sync operation and disable the up/down arrow keys. (This prevents the machine from joining another sync loop that is running and causing a fault on those machines when it drops off the loop.) To change the SYNC LOOP number, press the SYNC switch to deactivate. Set the loop number with the up and down arrow keys and press the SYNC switch again to activate. The LED on the SYNC switch indicates whether sync mode is active.

To run in sync the following conditions must be true:

1. A *sync cue* must be added to the beginning of the film. This is the first cue that is seen by the automation. It acts to initiate the start up sequence for each machine.
2. Sync Mode on each automation in the loop must be enabled.
3. The sync loop number on each automation in the loop must be the same.

To begin a movie, insure that the sync cue is positioned somewhere before the cue detector on the first machine. Press the [START] switch on any machine in the loop. All projectors will start simultaneously. As the sync cue passes through each projector, the show start sequence will initiate.

At the end of the show each machine will shut down independently as the tail of the film runs out of the projector. On endless loop systems all projectors will continue to run until the last machine sees the end cue. At that time all projectors will shut down simultaneously.

## System Status Messages

The CNA-150 contains a list of status messages that can be displayed due to various internal or external conditions. Most of these messages displayed indicate system faults. There are also some internal power up and reset diagnostic messages, most of which will not and should not be displayed under normal operating conditions.

## Fault Condition Messages

The Fault Condition messages can be divided into three categories: Internal *Memory* faults, *Local* faults and *Network* faults

## Memory Faults

The internal memory faults are generated when there is a "checksum" error. Briefly, a checksum is an arithmetic sum of the contents of memory that is stored in the memory itself and is re-computed and checked each time the CNA-150 is powered up.

### Program Memory Fault

MEM	FLT:PROG	1
	F a u l t	

Each of the Programs (1 through 9) have a checksum. The Program Memory Faults are indicated on the LCD display screen.

The Program Memory Faults are also displayed and "blinked" rapidly on the three LED displays.

<u>Message</u>	<u>Description</u>
<b>P 0 1</b>	Program 1 Checksum Fault
<b>P 0 2</b>	Program 2 Checksum Fault
<b>P 0 3</b>	Program 3 Checksum Fault
<b>P 0 4</b>	Program 4 Checksum Fault
<b>P 0 5</b>	Program 5 Checksum Fault
<b>P 0 6</b>	Program 6 Checksum Fault
<b>P 0 7</b>	Program 7 Checksum Fault
<b>P 0 8</b>	Program 8 Checksum Fault
<b>P 0 9</b>	Program 9 Checksum Fault

If any of the *Program* memory faults are displayed on power up, *clear* the fault by pressing the ALARM CANCEL key. Press the PROGRAM EDIT key to enter the edit mode. Cursor to the program that has the checksum error. Scroll through the program to verify that it has not changed. If all the steps look okay, press any key to re-calculate the checksum. Press the PROGRAM EDIT key again and cycle power to verify that there is no other checksum errors.

### Set-Up Parameters Memory Fault

A *Set-Up Parameters* memory fault will be displayed if there is a checksum error.

LCD display screen message:

**MEM FLT : SET-UP  
Fault**

LED Display message:

<u>Message</u>	<u>Description</u>
<b>P A r</b>	Set-Up Parameters Checksum Fault

If any of the *Set-Up Parameters* memory faults are displayed on power up, *clear* the fault by pressing the ALARM CANCEL key. Enter the Set-Up menu and verify all data. Correct any data errors and press the HOME key to re-calculate the checksum. Cycle power to verify that there is no other checksum errors.

## Synchronous Interlock Faults

Synchronous Interlock faults alert the operator that a problem exists with a CNA on the sync loop. These faults will either stop the show and sound the alarm or prevent a show from starting.

A **Local Sync Interlock Fault** is caused when either a master or one of the slaves in the sync loop has lost its sync input (sync switch). All CNA-150s on the sync loop will display “L S I” on the LED displays and sound their alarms. This message will also be displayed if one of the units on the loop had a “watchdog reset”. If this was the case, all units will display this message except for the one that had the watchdog reset.

LED Message:    **L S I**

LCD Message:

```

SYNC : I LOCK   ID = 1 2
      F a u l t
  
```

A **Local Sync Communications Timeout Fault** is caused when there is a loss of communications with a unit on the sync loop. This could be due to a loss of power of the master or one of the slaves on the loop. In this case all units on the sync loop would display “L S C” except for the one that lost its power. This fault can also be caused by defective wiring, such as an open or short on the LSN communications link.

LED Message:    **L S C**

LCD Message:

```

SYNC : T / O    ID = 1 2
      F a u l t
  
```

These next three faults indicate that the master or one of the slave CNA-150s is preventing the interlock loop from *starting* or *resuming* a show. The LED message is the same for these faults, but the LCD message is more descriptive.

The **Not Ready To Resume Fault** indicates that the automation cannot start a show because at least one of the CNA-150 remotes are not in the “Ready to Resume” condition.

LED Message:    **L S r**

LCD Message:

```

SYNC : RES     ID = 1 2
      F a u l t
  
```

The **Need Master To Resume Fault** indicates that there is no master. The master may be lost if the communication wires are disconnected, power is lost or the sync input (sync switch) is not enabled at the master.

LED Message: **L S r**

LCD Message:

**SYNC:NO MASTER  
Fault**

The **Not Ready To Run Fault** indicates that the automation cannot start a show because at least one of the CNA-150 remotes are not in the “Ready to Run” condition

LED Message: **L S r**

LCD Message:

**SYNC:RUN ID=12  
Fault**

The **Sync Remote Stop Fault** indicates a fault on a remote CNA when interlocked. The Sync Loop number will blink. Correct the problem to clear the message.

**SYNC:REMOTE STOP  
Fault**

## Local Faults

The **Local I/O Network Fault** is caused due to a loss in communications with a Local I/O Network device or another network problem. This could be the Booth Termination Panel, Console Termination Panel or other I/O Network device or a wiring problem.

A Local I/O Network fault will cause the CNA-150 to display "L I n". This fault will cause a shutdown during a show or prevent a show start between shows. This fault is latched and you are required to press the ALARM CANCEL key to clear the fault. Although this will cancel the fault and allow a show to start, there is a problem with the Local I/O Network or one of the devices and it must be repaired.  
LED Message: **L I n**

LCD Message:

L I N : N E T W O R K F L T  
F a u l t

The **Film Failsafe Fault** indicates that the film failsafe does not sense film presence or the film tension is excessive. Correct the problem to clear the message.

F I L M : F A I L S A F E  
F a u l t

The **Film Motion Fault** indicates that the film motion sensing device did not detect the proper film speed after 2 seconds. Press the ALARM CANCEL key to cancel the alarm.

F I L M : M O T I O N  
F a u l t - A l a r m

Press the ALARM CANCEL key again to clear the fault message.

F I L M : M O T I O N  
F a u l t

This fault indicates that the xenon lamp failed to light after 10 seconds. Press the ALARM CANCEL key to clear the message.

X E N O N L A M P F A U L T  
F a u l t

## Status Messages

CNA-150 status messages notify the operator that a particular action needs to be performed. The network start and stop messages let the operator know that a start or stop input is asserted either at a remote control station on the LSN or LIN.

```
LSN: REMOTE STOP  
Resume?
```

```
LSN: REMOTE START  
Running
```

```
LIN: REMOTE STOP  
Resume?
```

```
LIN: REMOTE START  
Running
```

This is the **Remote Alarm** status screen. This message indicates that a Fault-Alarm condition exists at a remote CNA-150, where the number is the CNA Id number.

```
REMOTE ALARM 12  
Running
```

The **Faults Defeated** message serves as reminder to the operator that the Film Presence, Film Motion, Film Tension and Xenon Faults are bypassed. Press the FAULT DEFEAT key to toggle this function on or off.

```
FAULTS DEFEATED  
Ready to Run
```

The **Low Battery Fault** indicates that the battery has gone below a pre-determined threshold voltage during a power down condition. If this message is displayed along with any memory fault messages, the low battery condition probably caused the other memory fault(s).

```
LOW BATTERY FLT  
Fault
```



## Power Up Messages

The CNA-150 will display two messages at a normal power up. The software version number, checksum number and type of reset will be displayed.

```
CNA-150    V3.150  
CHECKSUM = 6249
```

```
CNA-150    V3.150  
POWER UP RESET
```

## Additional Software

### CineNet Host Software Package

The CNA-150 automation is optimally configured and used with the CineNet HOST software package. The Host program allows setup, data transfer and programming in a user-friendly format. Additional hardware and software is required. First there must be a Host Computer, this can be any DOS-based PC with either 1 free ISA slot or an RS-232 Serial port that is not in use, installed on that PC there must be CineNet Host networking software. This software allows the PC to interface with the CNA. The only additional piece of hardware required is a network controller. This can be in the form of a ISA card installed in the PC, or a convenient external package such as the VNC or PCI-64 network interface.

See the CineNet HOST user manual for further details on installation.

Host software provides Event logging, both LIN and LSN Network status, configuration, and programming/ copy functions as described in previous sections.

### CineSuite Software Package

The CineSuite software package is a more advanced version of HOST software including three software applications:

*CineSuite Manager:* This is the main user interface. When creating CNA programs, settings CNA supervisory functions or monitoring CNA operations, this is the application that will be used.

*CineSuite Router:* The CineSuite Router is used to manage traffic between the various CineSuite applications. Users only need to set the client application to point to the computer that has the CineSuite router running and it can then communicate with all other clients connected to the same router.

*CineNet Driver*: This is the software application that connects the CNA Gateway and automations to the computer.

The CineSuite software operates over TCP/IP communications protocol meaning that it can be used in conjunction with the internet via a modem or any ethernet connection. It allows remote access to the automation network and provides a means of remotely monitoring devices on the LIN.

CineSuite Reporter software has a full color interface for quick identification of remote problems. Reporter can also email status reports managerial personnel and generate reports over long periods of time in order to quantify efficiency in staff and equipment.

CineSuite similarly requires a Host PC and a hardware interface device. The Host PC must be at least a 486/66Mhz running windows 95 or above. The CineSuite package is constantly under development with new features being added regularly. See the CineSuite Guide for additional information.

## Timing Diagrams for the CNA-150

The following Timing Diagrams show timer values, output configurations and cue events for all the outputs. These timing diagrams can be extremely useful to help understand the operation and capabilities of the CNA-150. The first timing diagram shows the “Standard Operation” from power up to show end. Standard Operation implies a running a program with no interruptions (stop or faults) or special effects (curtain call or intermission). The defaults for each outputs are indicated in the last column of the timing diagram. Default timer values and pulse durations are indicated in the bottom margin of the timing diagram. The diagram indicates automatic and programmed outputs.

The second timing diagram shows the Fault/Stop Shutdown and Restart Sequence. The area of interest is the shaded portion of the diagram. This shows the default ‘Fault-to’ conditions:

Projector Motor and Lamp = OFF  
Slide Projector = ON  
Changeover = CLOSE  
Sound = NON-SYNC  
House Lights = UP  
Stage Lights = UP

These default conditions can be configured in the CNA-150 Set-up Supervisory section of the Host PC Program.

The third timing diagram shows the Intermission Stop Sequence. The area of interest is the shaded portion of the diagram. At the Intermission cue the Changeover and Curtain will close. Seven seconds later the Projector Motor will shut off and the Slide Projector will turn on. Sound, Lights and Out 1, 2, 3, and 4 can be programmed for any state during the intermission. A Restart will start the Projector Motor and a film cue will initiate the show start sequence.

The fourth timing diagram shows the Curtain Call Sequence. The area of interest is the shaded portion of the diagram. The ‘curtain close time’ is determined by the distance between the curtain call cue and the next film cue. Sound, Lights and Out 1, 2, 3, and 4 can be programmed for any state during the Curtain Call.

The Last timing diagram shows the sequence for the Enhanced Curtain Call function. This is enabled during the DIP switch configuration at S2-2.

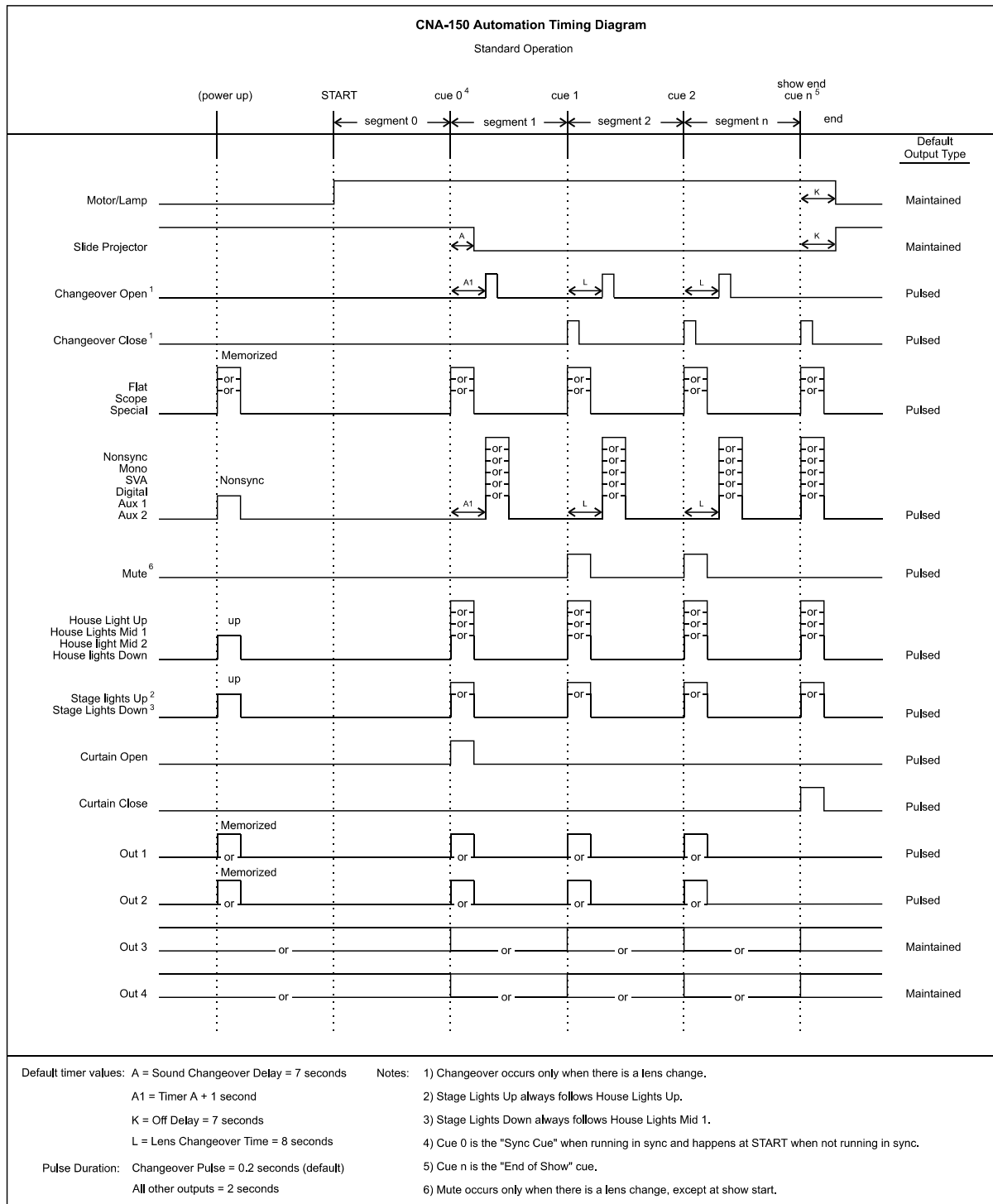

Timing Diagram 1

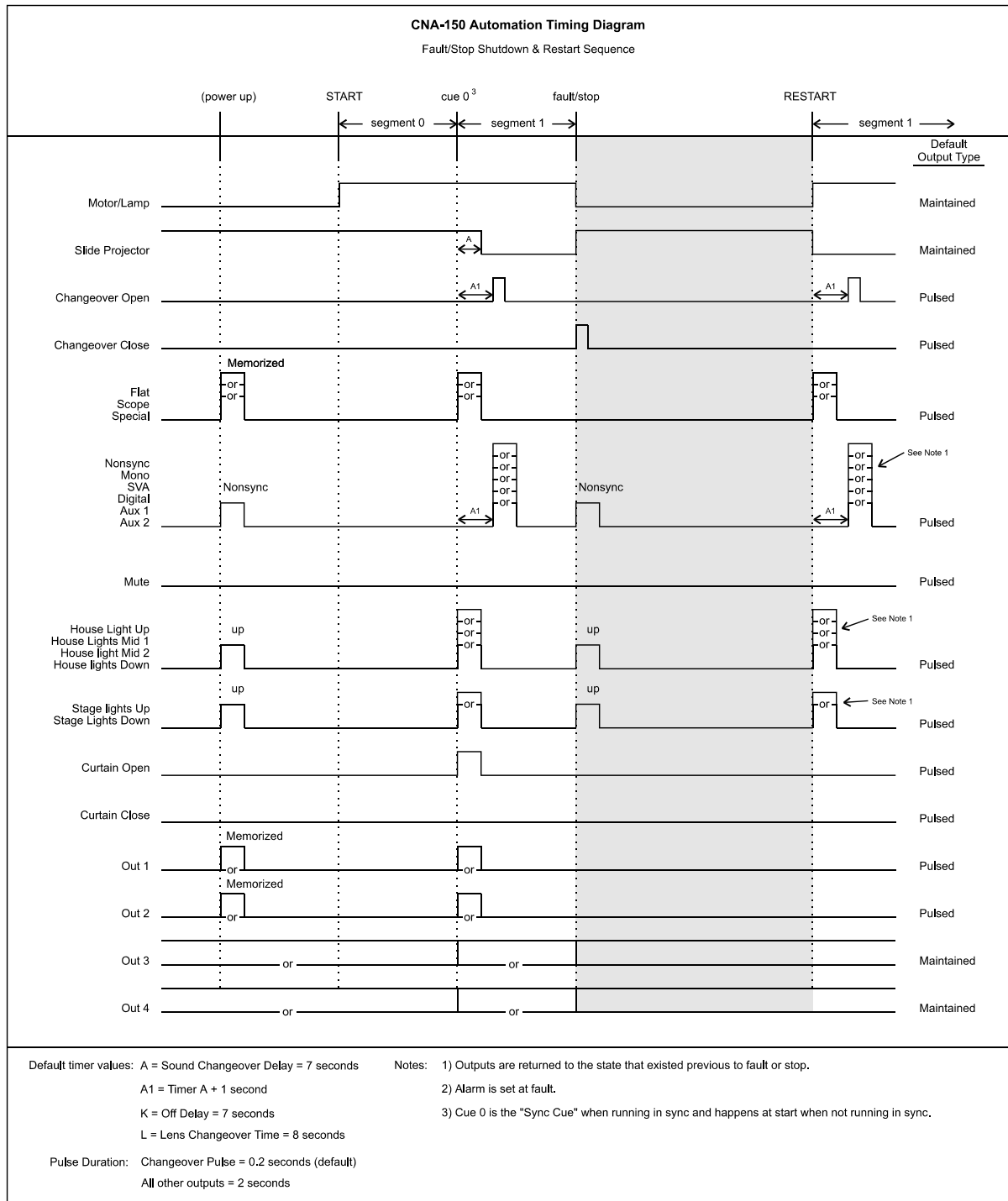

Timing Diagram 2

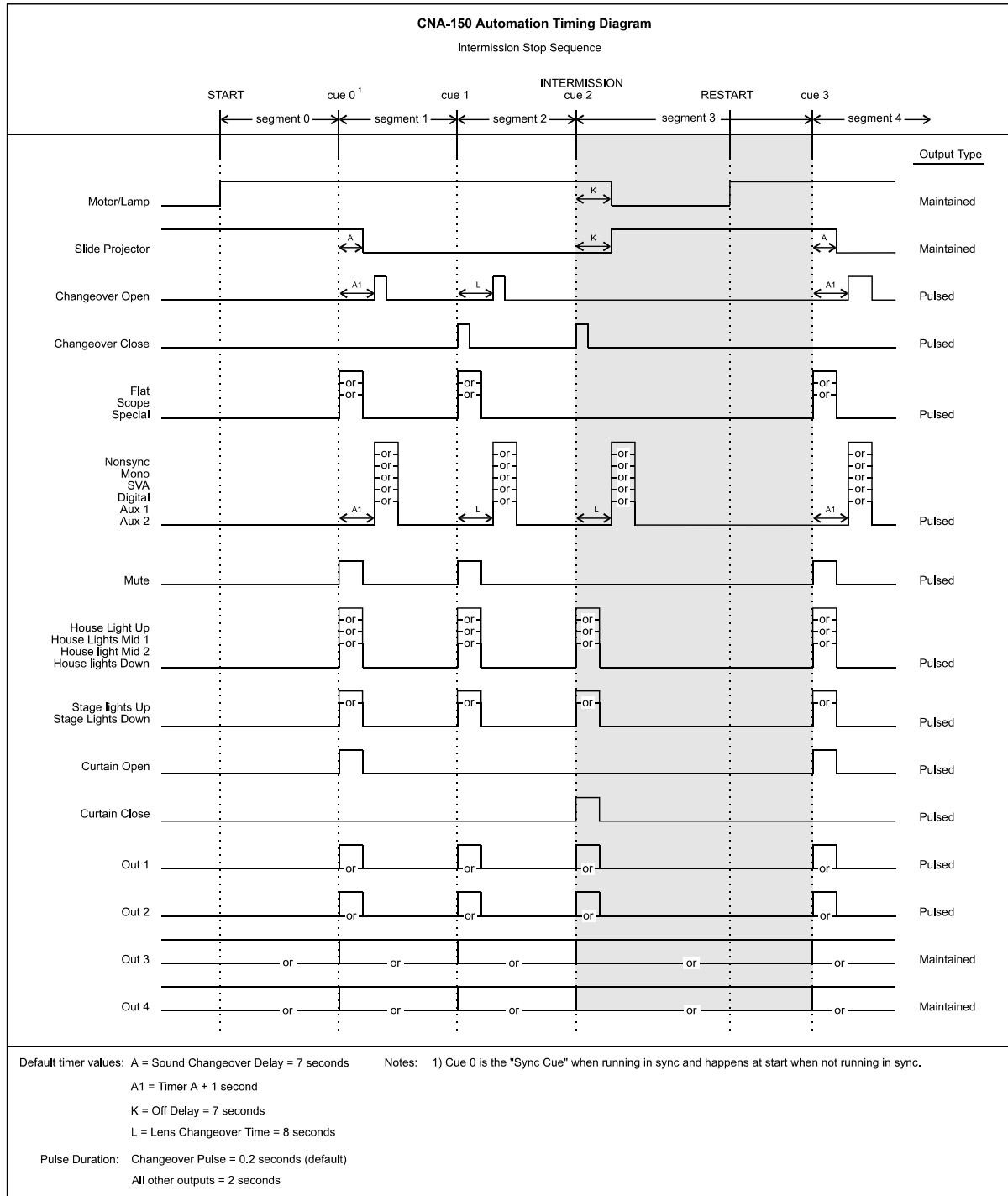

Timing Diagram 3

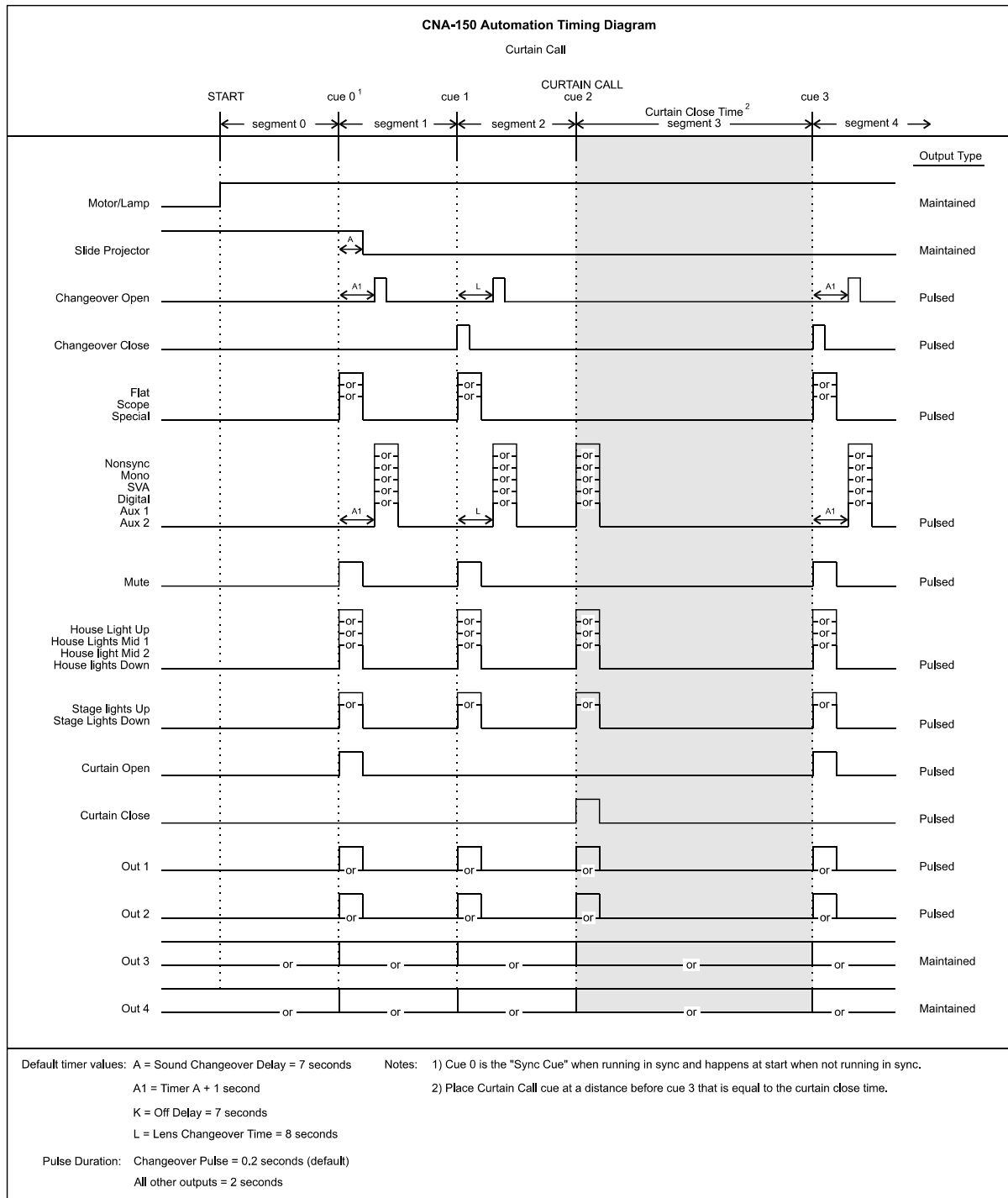

Timing Diagram 4

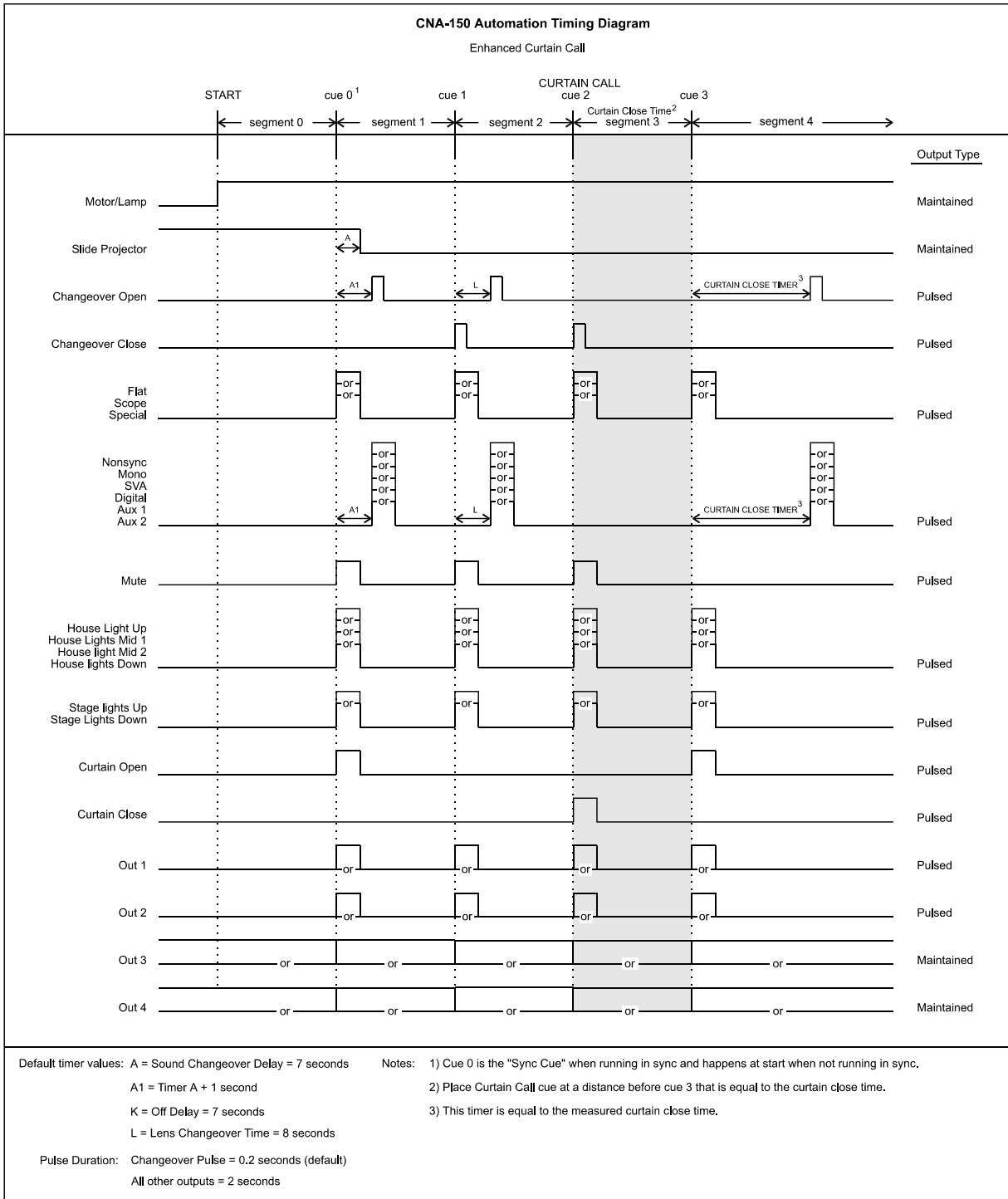

Timing Diagram 5



## Software Changes

This section lists CNA-150 Firmware change history and it's application notes

**Version: 3.00**  
**Checksum: 44532**  
**Date: 2/7/99**

Compatible with Host V.1.06, older versions of CNA 100 firmware, & CNA-200 V1.011.

New firmware auto-detects CNA-100/ 150 front panel

Added demonstration data entry support for QDC-400, there is no control or communications support implemented however

**Version: 3.01**  
**Checksum 49658**  
**Date: 3/4/99**

Compatible with Older CNA-100 Firmware, CNA-150 V2.00, CNA-200 V1.011  
QDC-400 V2 Host V1.06

Made internal software changes.(Fixed menu key vectors to always force the menu screen, top line is now cleared when error task is enabled)

**Version: 3.02**  
**Checksum: 44204**  
**Date: 4/27/99**

Compatible with older CNA-100, CNA-150 V2.02, CNA-200 V1.011, QDC V3

Dimmer Setup now allows 0-99 Seconds (Previous version allowed 0-60)

QDC v3 program now allows light level with 0 time to change immediately. this improves interoperability with the 150 because the 150 could be set to zero, the dimmer defaulted to 1.

**Version: 3.03**  
**Checksum: 54648**  
**Date: 6/22/99**

Compatible with Host 1.007, Older CNA-100 firmware, CNA-150 V2.03, CNA-200 V1.013

Unit now supports 4 QDC-400 Dimmer controls.

Added Cue Learn (manual/ auto/ disabled) flag.

Added timed start function.

Added Network copy programs and learn times w/ supervisory setup.

Menu system restructured for 150

Enabled SW2-6 Check focus delay function for timed start, on=enabled,

off=disabled

“Show End” LED blinks when waiting for cue 9

added 4 flags to system parameters, this will allow the operator to drive any spare relays that may be available. These are as follows:

1 CURTAIN CLOSE 2 CURTAIN OPEN 3 ENVIRONMENT 4 HOUSE  
DOWN 5 HOUSE MID 1 6 HOUSE MID 2 7 HOUSE UP 8 LENS FLAT 9  
LENS SCOPE 10 LENS SPECIAL 11 MASK FLAT 12 MASK SCOPE 13  
MASK SPECIAL 14 PREAMP 1 15 PREAMP 2 16 SLIDE PROJ B 17 SLIDE  
PROJ C 18 SOUND AUX 1 19 SOUND AUX 2 20 SOUND DIGITAL 1 21  
SOUND DIGITAL 2 22 SOUND MONO 23 SOUND MUTE 24 SOUND  
NON-SYNC 25 SOUND SR

show end led no longer blinks when the previous show was a cue 9 show.

**Version: 3.04**

**Checksum:**

**Date: 8/23/99**

Compatible with Host V1.007, Older CNA-100 versions, CNA-150 V2.040,  
CNA-200 V1.014, RVC10 V1, QDC-400 V3+4

Added event logging via SW2-7 (on=enabled, off=disabled)

Added measurement of "Unscheduled Down Time". This is simply the number of seconds that a show is stopped due to a Major Fault or by Manual "Stop" (key or input).

Primary Start Mode (PSMODE) is now cleared when "STOP & START" keys are pressed for show abort sequence. (Now same as CNA-200.)

Added Network Command \$36 "Event Buffer Management"

**Version: 3.05**

**Checksum: 25650**

**Date: 2/4/2000**

Compatible with Host V1.010, Older CNA-100 firmware (V1.08), CNA-200  
V1.016, QDC-400 V3+4.

<<< Now requires CNABOOT program for power up vectors >>>

Added support for Flash updates through Host

SW1-1 Now forces Bootloader in the event of RTOS failure.

Added “remote reset” power up message for occasions where a remote reset is invoked.

Fixed Slide Projector on Booth Board when not configured for Fire Stop Operation (SW2-4). This output was disabled starting with Versions 1.011.

**Version: 3.06**  
**Checksum:**  
**Date: 5/11/2000**

Compatible with Host V1.010, Older CNA-100 firmware (V1.08), CNA-200 V1.016, QDC-400 V3+4.

Improved keypad cue input functionality,  
Moved sound and lights default code to the start stop key abort logic and removed it from the DRMABT routine. This prevents Show start from forcing House and Staged lights up and sound to Non-sync when waiting for Cue 0

**Version: 3.07**  
**Checksum: 53624**  
**Date: 6/28/2000**

Compatible with Host V1.011, Older CNA-100 firmware (V1.08), CNA-200 V1.019, QDC-400 V3+4.

Added support for new "FIRESTOP" input bit from RCM10 V2.020 Sync flags. Compatibility and functionality are described below. Note that "Remote Stop" and "Fire Stop" are two different functions:

-RSM10 V2.01 -Estop input asserts Remote Stop to each of it's 10 CNA's (Causes "normal" shutdown in all CNA's.)

-RSM10 V2.02 -Estop input asserts Remote Stop to each of it's 10 CNA's.(Causes "normal" shutdown in all older CNA's.) In addition a new (spare) bit is also asserted which is defined as "FIRESTOP". (Causing "FireStop Faults in all newer CNA's.)

CNA-200 V1.018 -If ESTOP is asserted at the RMC10 (V2.01 or V2.02) the CNA-200 performs a normal "REMOTE STOP".

CNA-200 V1.019 -If ESTOP is asserted at an RMC10 V2.01 the CNA-200 performs a normal "REMOTE STOP".

-If ESTOP is asserted at an RMC10 V2.02 the CNA-200 asserts it's FireStop Fault.

All combinations are compatible - you will either get the "old" operation or the "new" operation. To get the "new" operation, you need to update both the RCM and the CNA software.

Note the SW2-4 operation is unchanged in this software release - it is stated here for convenience since there is now an additional input that can set the Fire Stop Fault.

**Version: 3.08**  
**Checksum:54131**  
**Date: 6/8/2001**

Fixed scan related "blip" on Non-sync output when Fire Stop input was asserted.

**Version: 3.09**  
**Checksum: 62998**  
**Date: 9/25/2002**

Added support for Kodak Content Player (Network 2) on the existing Debug Port (P6).

This Kodak Content Player feature is Enabled/Disabled with DIP Switch 2 bit-8. All Manual Start Inputs (including the new one from Kodak) now support the "Check Focus" delay. See DIP Switch 2 bit-3.

Added the following new Error Messages:

"CAI COM TIMEOUT"  
"CP COM TIMEOUT"  
"CP NOT IN AUTO"  
"CP NOT READY"

**Version: 3.10**  
**Checksum:**  
**Date: 10/31/2002**

Made internal improvement with "firestop" input function.(could have resulted in a switch to a sound format if the fire stop input was asserted for only 1 scan.)

**Version: 3.11**  
**Checksum: 6450**  
**Date: 1/16/2003**

Added SW3-1 configuration to enable "Program Edit Key Password" logic.

SW3-1:  
ON "Program Edit Key Password" required.  
OFF "Program Edit Key Password" is not required.

When configured with "SW3-1 ON", the software supports both the original "Edit" mode and a new "View Only" mode.

The "View Only" mode is indicated by the "Program Edit LED" blinking.

This new mode allows the Feature Programs to be viewed by anyone. However, changing programs (may) now require entering the correct password.

**Version: 3.12**  
**Checksum: 64280**  
**Date: 1/16/2003**

Internally changed communications error reporting program.(Added CLINK2TMR to prevent erroneous "CAI COMMUNICATIONS TIMEOUT" error messages. The previous version could "blip" the error message for valid communications retries. The error should now only be set if communications is down for the intended 8 seconds.

**Version: 3.13**  
**Checksum: 57080**  
**Date: 10/21/2003**

Added "chksys" logic to data entry save of system parameters eliminating unnecessary LIN traffic. Where updates are only performed when data changes  
Added support for new QDC v7 Optional front panel.  
Screens that edit system parameter data are aborted by communications if system parameter is received from a QDC board. This applies to the following screens: setup CNA system and Setup dimmer.

Added support for QDC overrides from boards 2-4.  
Changed power up logic to now finish move to save system parameters from the QDC update if it was interrupted by a power failure.

**Version: 3.14**  
**Checksum: 40242**  
**Date 4/20/2004**

HDLCs no longer clears HOSTUP flag. (made the CNA request Host ID and then Send machine status via LSN  
Reworked software to prevent unwanted watchdog tripping when debugging.  
Added Support for RVC-5, "3-sound" in supervisory, "3-sound programs" to set-up menu, and "3-sound level" to control menu.  
Enhanced support for ACP 50 volume keys and display.  
The rising edge of firestop fault logic now forces house and stage lights bright. This lets the overrides function as expected. Previously the lights were not forced bright if a fault was present.

**Version: 3.15**  
**Checksum: 6249**  
**Date: 1/19/05**

1- Added new password control features:

(Note: Latest version (1.016) of Host program required for remote change)

Software override of DIP switch 2-5 password enable setting permits user to administer password setting regardless of switch position. This feature is enabled via a Host PC. Options are:

Default Use traditional control, switch 2-5 enables/ disables system password

Off No password required to access setup/ programming parameters.

On Password always required, switch 2-5 has no effect.

Feature is accessible locally via the CNA's setup menu.

2- Switch 3-6 now disables/ enables the check focus delay alarm on the RCM-10/ RSM-10 Remote station when the CNA starts a show.

Switch definitions:

Off Enable RSM-10 Check focus alarm

On Disable RSM-10 Check focus alarm

3- Added programmable power-up states for the following:

Masking (Flat, scope, special, none, No-Op)

Sound (Non-Syn, Mono, SVA, SR, Dig 1, Aux 1, Dig 2, Aux 2, Mute off, Mute on, No-Op)

4- Added programmable "fault-to" states for the following parameters, these are the settings defaulted to after a fault is encountered:

Lens (Flat, Scope, Special, None, No-Op)

Masking (Flat, Scope, Special, None, No-Op)

Sound (Non-Syn, Mono, SVA, SR, Dig 1, Aux 1, Dig 2, Aux 2, Mute off, Mute on, No-Op)

House Lights (Up, Down, Mid 1, Mid 2, No-Op)

Stage Lights (Up, Down, No-Op)

5- Corrected start time routine to function more like CNA-200, this improves interoperability with the content player. Also fixed call to log "Automatic cue 0 event" to ensure event log accuracy.

**Bootloader Changes:****Date: 2/4/2000****Version: 1.000****Checksum: 40157 (Base 10)**

Initial bootloader used in CNA system.

1. Created this Boot Loader Program to load the following programs into FLASH:

- CNA-100 V2.05
- CNA-150 V3.050
- CNA-200 V1.016

2. This program uses LSN Network Device Type = 4 (CNABOOT).

3. Now supports LSN FLASH update Network commands (\$40 to \$43).

**Date: 5/9/2000****Version: 1.001****Checksum: 44570 (Base 10)**

1. Moved "LDY #SWAPCNT" up 3 lines in Calculate Checksum routine (CALCPCHK) to increase the rate the watchdog is toggled. Should not have been a problem.

2. Now toggles watchdog in FL\_PROGBK routine since a byte write may take as long as 60 milliseconds

**Date: 9/16/2002****Version: 1.010****Checksum: 44558 (Base 10)**

Latest versions at this time:

- CNA-100 V2.09
- CNA-150 V3.090
- CNA-200 V1.022

1. Changed "CPE SAVEP,Z" to "CPE 0,X" in FL\_PROG routine to correctly test for "POSSIBLE TIMEOUT OR JUST WENT DONE". The previous logic might report a write as failed. The logic must be currently taking the earlier branches - Since there were no reports of this failure from the field at this time.

**Date: 10/7/2002**

**Version: 1.020**

**Checksum: 61822 (Base 10) \$F17E**

Latest versions at this time:

CNA-100 V2.09

CNA-150 V3.090

CNA-200 V1.022

1. Rewrote FL\_ERASE routine. The original interpretation of the multiple sector erase sequence was wrong - but worked with the FLASH parts at that time ("non-lettered": AM29F010). However the new parts ("lettered" AM29F010B) no longer accept this interpretation. Basically, the "unlock" portion of the command should only be issued once, then within 50 microseconds write the Sector Erase command (\$30) to multiple sectors.
2. Reworked the comments for FL\_ERASE - Indicating it should only be used to erase a single sector.
3. Moved call to "PROTFY" in main loop down a few lines from just after "JSR FL\_ERASE" to just after "JSR FL\_WAITE". I don't think this was a problem, since this program runs in ram. This change should now let the "FL\_ERASE" routine correctly perform the FLASH Reset function if it is ever necessary.
4. Increased FLASH erase timeout from 15 to 20 seconds.



## Index:

Alarm	16
Alarm Cancel	6
Check Cue fault	25
Check Focus Alarm	41
Check Focus delay	14
Checking the Network	17
Control	34
Copy	32
Copy, Local	33
Copy, Network	32
Cue Factor	24
Cue factor default	24
Cue input	6
Cue Learn Function	41
Cue learn Mode	25, 34
Cue Number	5
Cue Time	24
Cue Window	42
Cue Window Factor	42
Curtain Call key	38
Description	3
DIP switches	11
Display Messages, Memory	46
Failsafe delay	24
Fault Messages	45
Fault Messages, Memory	45
Intermission key	38
Introduction	1
Keypad	5
Learn mode	34
Learn Times	28
Learned mode	34
Lens Changeover	24
Lens Changeover Delay	24
Lens Changeover Pulse	24
LIN	3
Local faults	49
Loop number	6
LSN	3
Memory Faults	45
Menu Structure	19
Missed Cue fault	25
Network Copy	32
Network Status	30
Next State	40
Operation	40
Operator interface	4
Overrides	40

Power up Messages .....	51
Product description .....	3
Program edit .....	5
Program Memory Fault .....	45, 46
Program Number .....	5
Programming .....	36
Remote Stop Alarm Time .....	26
Revision History .....	58
Setup .....	11
Setup Dimmer .....	27
Setup, Learn Times .....	28
Software Changes .....	58
Software Revision History .....	58
Sound Changeover Delay .....	23
Sound level .....	35
Start .....	5
Start Mode .....	34
Status LED's .....	16
Status Messages .....	45, 50
Stop .....	6
Structure, Menu .....	19
Sync .....	6
Sync cue .....	45
Synchronous Interlock Faults .....	47
Synchronous Operation .....	44
System .....	4
System Overview .....	2
Termination Panel, Booth .....	9
Termination Panel, Console .....	8
Termination Panel, Dual .....	8
Termination Panel, Single .....	7, 10
Termination Panels .....	7
Timed Start .....	25, 34
Timing Diagrams .....	52

### List of Illustrations:

- Figure 1: Operator interface- Page 5
- Figure 2: DIP Switch Configuration- Page 11
- Figure 3: DIP Switch ID# table- Page 13
- Figure 4: Status LED's and Alarm Loudness jumper- Page 16
- Figure 5: Keypad illustration- Page 36
- Timing Diagram 1: Normal Operation- Page 53
- Timing Diagram 2: Fault/Stop Shutdown and Restart Sequence- Page 54
- Timing Diagram 3: Intermission Stop Sequence- Page 55
- Timing Diagram 4: Curtain Call- Page 56
- Timing Diagram 5: Enhanced Curtain Call- Page 57

**CNA-150 Parts List:**

Below is a listing of the major components that make up the CNA-150, the technician or theatre manager may find it useful when ordering replacement parts in the event of an automation component failure.

Description	OEM#	Strong#
CNA-150 Display interface board	39324-PCB	-NA-
CNA-150 CPU Mainboard	39325	5172008
CNA-150 Replacement Overlay w/ Front panel	39521-1	-NA-
CNA Power supply	39328	5198304
CNA Replacement power transformer	64011	-NA-
CNA-150 Wall-Mount Replacement Overlay w/ Front panel	39374-1	-NA-
DPST Rocker Switch, Power and Overrides	39336	-NA-
SPDT Rocker Switch, Overrides	39337	-NA-
SPDT Rocker Switch, Overrides	39338	-NA-

**Note:** Other specific parts available upon request, contact Strong International for assistance.